

Electronic controllers AKOTIM



Used to control the temperature in cold generators and display the information of the historical operation, the refrigeration period, the defrost period and the total cycle. Very useful for the self-checking in Nourishing Security, see point 7 about AKOTIM function.

Index

- 1- Versions and references
- 2- Technical data
- 3- Installation
- 4- Maintenance
- 5- Warnings
- 6- Front panel functions
- 7 - Function AKOTIM
- 8 - Parameters transfer
- 9 - PC Communication
- 10 - Displaying
- 11 - Programming
- 12 - Menus, Parameters and Messages

1. VERSIONS AND REFERENCES

Depend on versions and references include:

- Relay 1 **COOL** to control the compressor or solenoid.
- Relay 2 **R2** for defrost or fans, in 2 relays versions.
- Relay 2 **DEF** for defrost in versions of 3 or more relays.
- Relay 3 **FAN** to control the fans in versions of 3 or more relays.
- Relay 4 **ALARM** for alarms.

The versions with more than one relay have an additional input for temperature sensor that permits the defrost end by temperature. The reference + A it means a version with relay 4 ALARM additional for alarms.

Power supply 50/60 Hz		230 V~ ±10%	12 V≈ ±20%	120 V~ +8% -12%	
1 Relay 1	Defrost by compressor stop	Panel mounting	AKOTIM-11	AKOTIM-14	AKOTIM-17
		DIN rail mounting	AKOTIM-21	AKOTIM-24	AKOTIM-27
2 Relays 1+2	Compressor + defrost or fans	Panel mounting	AKOTIM-12	AKOTIM-15	AKOTIM-18
		DIN rail mounting	AKOTIM-22	AKOTIM-25	AKOTIM-28
3 Relays 1+2+3	Compressor + defrost + fans	Panel mounting	AKOTIM-13	AKOTIM-16	AKOTIM-19
		DIN rail mounting	AKOTIM-23	AKOTIM-26	AKOTIM-29

The reference + **R** it means a version with real time clock.
 The reference + **T** it means a version with an input for a third temperature sensor.
 The reference + **E** it means a version with a digital input.
 The reference + **B** it means a version with a buzzer of internal acoustic alarm.

Examples: **AKOTIM-12RB** it means **AKOTIM-12** with real time clock and buzzer of internal acoustic alarm.
AKOTIM-12ARTEB it means **AKOTIM-12** with the 5 options included.

REMARK: A reference number followed by /**, one or two alphanumeric characters, means «with a special program». In such a case, in addition to these general instructions, the particular instructions attached, with variations for each device should be followed.

2. TECHNICAL DATA

Temperature range: (-58°F to 211°F) -50°C to 99°C
 Inputs for NTC sensors:..... **AKO-149XX**
 Total accuracy (Sensor +controller):..... ±1°C
 Relay 1 **COOL**: 16(4)A*, 250V, cosφ=1, SPST
 Relay 2 **DEF** or **R2**: 8A*, 250V, cosφ=1, SPDT
 Relay 3 **FAN**: 5A*, 250V, cosφ=1, SPST
 Relay 4 **ALARM**: 5A*, 250V, cosφ=1, SPST
 Max. input power versions 12V: 3VA
 Max. input power versions 230V and 120V: 5VA
 Working ambient temperature: 5°C to 40°C
 Storage ambient temperature: -30°C to 70°C
 Installation category:..... II under CEI 664 standard
 3 digits and optional decimal point by program
 Double insulation between power supply, secondary circuit and relay output.
 * The current specified for each relay is its individual maximum, if more than one is connected, the sum current (COOL + DEF + FAN) should not exceeded 17,5A (EN61010) or 13A (EN60730).

3. INSTALLATION

The controller must be installed in a place protected from vibrations, water and corrosive gases, and where the ambient temperature does not surpass the values specified in the technical data.
 In order for the panel mounting controllers to be suitable having IP65 protection, the gasket should be installed properly between the apparatus and the perimeter of the panel cut-out where it is to be fitted.
 In order to give a correct reading, the sensor has to be installed in a place without heat influences other than the temperature that is to be measured or controlled.

3.1 Fastening units for panel mounting

To fix the unit, place the fasteners **1** over the sliders **2** as shown in the figure. Move the fasteners in the direction of the arrow. By pressing tab **3** the fasteners may be moved in the opposite direction of the arrow.

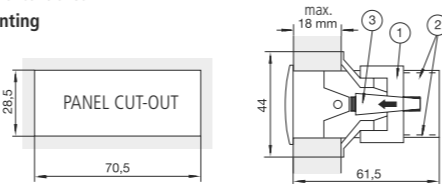

3.2 Fastening units for DIN rail mounting

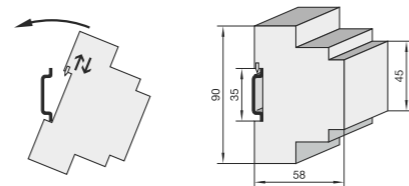

3.3 Connection

See diagram in the unit rating plate.
 The probe and its lead should **NEVER** be installed in ducting along with mains, control or power supply wiring.
 The power supply circuit should be connected with a minimum 2A, 230V, switch located close to the unit.
 The power supply cable should be of the type H05VV-F 2x0,5mm² or H05V-K 1x0,5mm².
 Section of connecting wires for relays contacts must be between 1mm² and 2,5mm²

4. MAINTENANCE

Clean the surface of the units with a soft cloth and soap and water. Do not use abrasive detergents, petrol, alcohol or solvents.

5. WARNINGS

The use of the unit different to the manufacturer's instructions voids the safety qualification.
 To ensure correct operation of the apparatus, only NTC type probes supplied by AKO should be used.
 Between -40 °C and +20 °C, when probes is extended with minimum 0,5mm², up to 1000m cable, deviation will be less than 0,25 °C (sensor prolongation cable ref. **AKO-15586**).

6. FRONT PANEL FUNCTIONS

6.1 Panel mounting models



DOWN key
 When pressed for at least 5 seconds, it displays the SET POINT temperature value.

6.2 DIN rail-mounting models

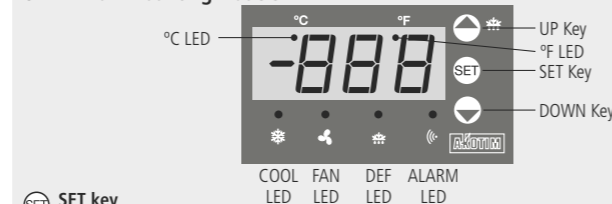

SET key
 When pressed for at least 5 seconds, it displays the SET POINT temperature value.

6.3 Common functions:

- UP key**
 When pressed for at least 5 seconds, a manual defrost is started with programmed duration.
 In programming, it increases the value being displayed.
 It cancels the alarms, but they remain displayed.
 Press once to entry in displaying menu.
- DOWN key**
 In programming, it decreases the value being displayed.
 It cancels the alarms, but they remain displayed.

- °C LED** **permanent:** It means displaying temperature in °C.
- °F LED** **permanent:** Set Point or parameter programming phase.
- COOL LED** **permanent:** It means displaying temperature in °F.
- FAN LED** **permanent:** Refrigeration COOL relay (compressor) is energised.
- DEF LED** **permanent:** Control FAN relay is energised.
- ALARM LED** **permanent:** Indicates DEFROST in operation.
- ALARM LED** **permanent:** ALARM relay energised (or acoustic alarm).
- flashing:** Alarm detected, relay de-energised, but display maintained.

Graphic representation of the AKOTIM concepts in one example of complete cycle where:

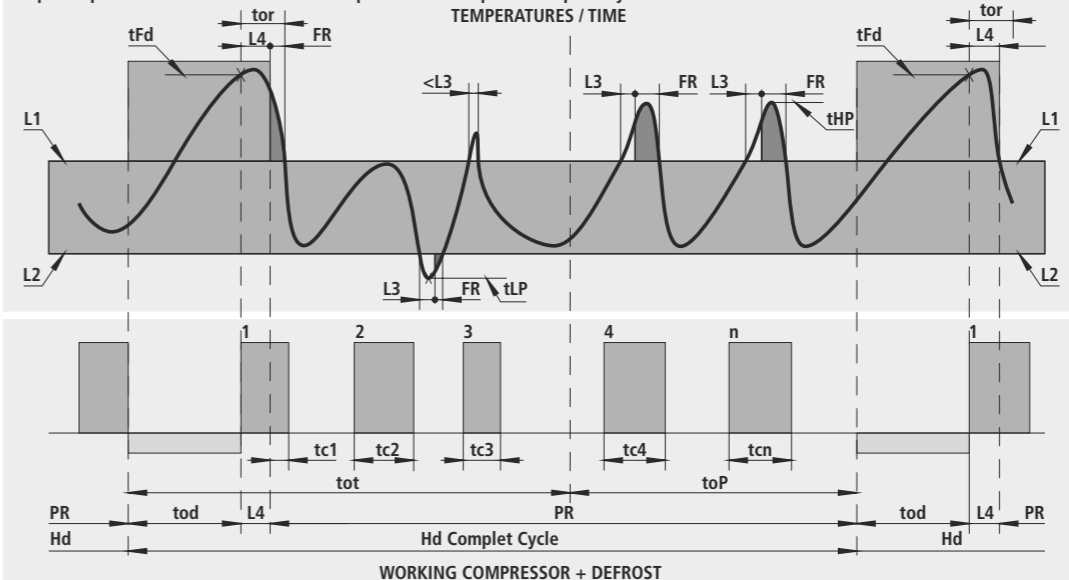

8. PARAMETERS TRANSFER

AKO-14918

A portable server without supply to which, the parameters programmed in **AKOTIM** powered units with communication connector can be copied. The parameters may then be transferred from the sever to other identical powered units.

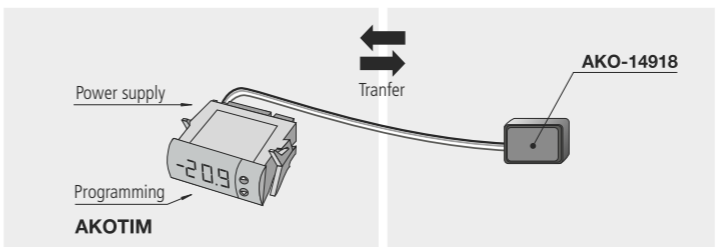

7. FUNCTION AKOTIM

Programming this function in P2 of parameters you can display (limitable by password L5) the data of the last complete 4 cycles **Hd**:
Instantaneous and total information on the cycle:
tot Time elapsed from the last defrost (hours).
toP Time to go for the next defrost (hours).
PrE Percentage time inside rating conditions (%).
Information on the cycle refrigeration period:
tHP Maximum temperature reached (°C/°F).
tLP Minimum temperature reached (°C/°F).
PCo Percentage time with the control relay (compressor) energised (%).
nAC Number of connections per hour of the control relay (compressor) (Num./hour).
Information on the cycle defrost period:
tod Defrost duration time (minutes).
tFd Final defrost temperature (°C/°F).
tor Time to recover temperature after defrosting (minutes).

- L1** Parameter of max. temperature admitted in refrigeration period
- L2** Parameter of min. temperature admitted in refrigeration period
- L3** Parameter of max. partial time admitted outside rating conditions
- L4** Parameter of max. time admitted to recover temperature after defrosting
- tc** Partial time with control relay (compressor) energised
- n** Number of connections in a complete cycle
- FR** Partial time outside rating conditions
- PR** Refrigeration period time

In the calculations for values **PrE**, **nAC** and **PCo** the controller apply the formulas:

$$PrE = \frac{PR - \sum FR (min)}{PR (min)} \times 100$$

$$nAC = \frac{n}{PR (h)}$$

$$PCo = \frac{\sum tc (min)}{PR (min)} \times 100$$

Zone where the working conditions are correct with the pre-set ones. Out of this zone the controller displays the temperature flashing with the messages UP if the tendency is to rise or dn if the tendency is to lower.

9. PC COMMUNICATION

The controllers **AKOTIM** are provided with a communications connector, permit data transmission and reception using the standard **MODBUS** protocol and to carry out management from PC software. This makes a centralised system for display, logging, alarms, remote teleprocessing ...

AKO-5003

Software for controllers and data loggers using a PC type computer.

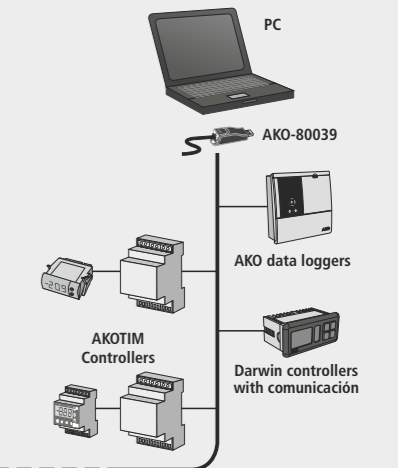

Up to 126 units and 1200m length. When over 32 units are installed the appropriate **AKO-80024** repeaters are needed.

10. DISPLAYING

Level 1 Menus and values Pb of temp. in sensors

- Press the key **▲**. The LED "°C" will be flashing and in the display will appear the first menu **ALS** if any alarm is activated, follows **tid** of AKOTIM menu if it is programmed in P2 and not limited by L5, follows the values **Pb** of the temperature in each sensor.
- Press the key **▲** to access the next display and the key **▼** to return the previous one.
- Press the ACCEPT keys to access at Level 2. Pressing ACCEPT keys in the last display EP the controller will return to the current temperature display status and the LED "°C" will stop flashing.

Level 2 Displaying alarms and selection of last cycles

- When we are in the menu selected in Level 1, press the ACCEPT keys to display in **ALS** menu the type of alarm activated or select in **tid** menu the cycle of the 4 last ones that you wish information.

Level 3 Values (flashing)

- When we are in the cycle selected in Level 2, press the ACCEPT keys to display the information values.

Press the key **▲** to access the next value and the key **▼** to return the previous one.

NOTE: If no key is pressed for 25 seconds in any of the previous steps, the controller will automatically return to the current temperature display status.

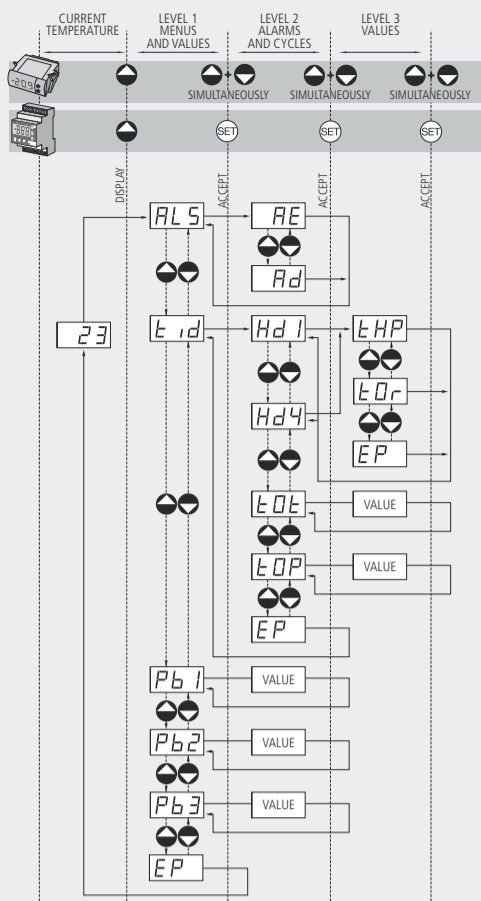

Level 1 Menus and values				
ALS	Level 2 Alarms menu (if any is activated)			
AE	Extern alarm activated of the digital input P9 = 2			
AH	The Sensor 1 temperature exceeds that programmed in A1			
AL	The Sensor 1 temperature is lower than that programmed in A2			
Ar	Low-charge clock battery or non-programmed clock alarm. If over 36h is disconnected the clock needs new programming.			
Ad	Alarm activated if defrost ends by maximum time and A8 = 1			
tid	Level 2 AKOTIM information menu (if programmed in P2 and not limited by L5)			
Hd1	Cycle 1 Information, last complete			
	Level 3 Values of each cycle (flashing with concept)			
tHP	Maximum temperature reached in refrigeration period	Min. -50	Max. +126	
tLP	Minimum temperature reached in refrigeration period	°C/°F	-50	+126
PCo	Percentage time with the control relay (compressor) energised	0%	100%	
nAC	Number of connections per hour of the control relay (compressor)	0	99	
PrE	Percentage time inside rating conditions	0%	100%	
tFd	Final defrost temperature	-50	+126	
tod	Defrost duration time	0 min	99 min	
tor	Time to recover temperature after defrosting	0 min	99 min	
EP	Level 3 exit			
Hd2	Cycle 2 Information, anterior at 1			
Hd3	Cycle 3 Information, anterior at 2			
Hd4	Cycle 4 Information, anterior at 3			
tot	Time elapsed from the last defrost	0 h	99 h	
toP	Time to go for the next defrost	0 h	99 h	
EP	Level 2 exit			
Pb1	Probe 1 value (S1-TEM of control) during 25 seconds			
Pb2	Probe 2 value (S2-DEF of evaporator) during 25 seconds (if programmed P4)			
Pb3	Probe 3 value (S3 Independent of control) during 25 seconds (if programmed P4)			
EP	Level 1 exit			

11. PROGRAMMING

ADJUSTING THE SET POINT TEMPERATURE

- The factory default value is 0 °C.
- Press the DISPLAY SET POINTS key for at least 5 seconds, it displays the current value and the LED "°C" start flashing.
- Press the **▲** or **▼** key to adjust the SET POINT to the required value
- Press the ACCEPT keys to set the new value. When this operation is carried out, the display will return to the current temperature display status and the LED "°C" stop flashing.

PARAMETERS

The parameters should only be programmed or modified by personnel who are fully acquainted with the operation and possibilities of the equipment where it is applied.

Level 1 Menus

- Press the **▲** + **▼** keys simultaneously for at least 10 seconds. The LED "°C" will be flashing programming phase and in the display will appear the first menu "rE".
- Press the **▲** key to access the next menu and the **▼** key to return the previous one.
- Pressing ACCEPT keys in the last display EP the controller will return to the current temperature display status and the LED "°C" will stop flashing.

Level 2 Parameters

- Press the ACCEPT keys in the menu selected, the first parameter of menu will appear in the display.
- Press the **▲** key to access the next parameter and the **▼** key to return the previous one.
- Pressing ACCEPT keys in the last display EP the controller will return to Level 1 of menus.

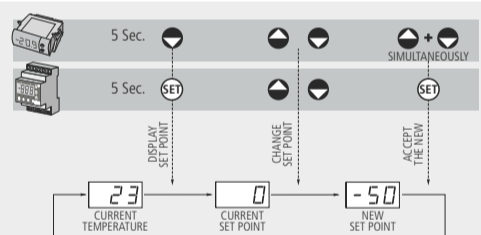

Level 3 Values

- To display the current value of any parameter, select the required one and press the DISPLAY VALUE keys. Once it is displayed, it can be modified by pressing the **▲** or **▼** keys.
- Press the ACCEPT THE NEW keys to set the new value. When this operation is carried out, the programming return to Level 2 (parameters).

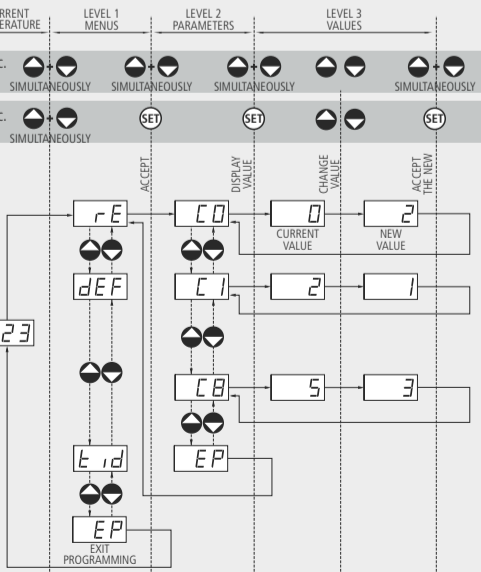

NOTE: If no key is pressed for 25 seconds in any of the previous steps, the controller will automatically return to the current temperature display status without modifying any of the parameters values.

12. MENUS, PARAMETERS AND MESSAGES

The values in the Def. column are factory-set. If a reset is performed by means of the P3 programming parameter, it will automatically take the values listed in Def. column.

Level 1		Menu			
rE	Level 2	REFRIGERATION (Compressor) control parameters			
	Level 3	Values	Min.	Def.	Max.
C0	Sensor 1 calibration (Offset)	°C/°F	-20	0	+20
C1	Sensor 1 differential (Hysteresis)	°C/°F	1	2	20
C2	Set point upper limit (it cannot be set above this value)	°C/°F	XX	99	126
C3	Set point lower limit (it cannot be set below this value)	°C/°F	-50	-50	XX
C4	Compressor protection delay time: 0 = OFF/ON (from the last to switch-off) 1 = ON (at switch-on)		0	0	1
C5	Protection delay time (value for the option selected by parameter C4)		0 min.	0 min.	99 min.
C6	"COOL" relay (compressor) status with faulty sensor 1 0 = OFF 1 = ON 2 = OFF/ON (to programmed in C7 and C8)		0	1	2
C7	"COOL" relay (compressor) ON, time in case of sensor 1 failure If C7 = 0 and C8 ≠ 0, the relay will always be OFF de-energised		0 min.	10 min.	99 min.
C8	"COOL" relay (compressor) OFF, time in case of sensor 1 failure If C8 = 0 and C7 ≠ 0, the relay will always be ON energised		0 min.	5 min.	99 min.
dEF	Level 2	DEFROST (electric heat / hot gas bypass) control parameters			
	Level 3	Values	Min.	Def.	Max.
d0	Elapsed time between 2 starts		0 h	6 h	99 h
d1	Maximum duration (if not ended by temperature will do by time)		0 min.	30 min.	99 min.
d2	Type of message during defrost: (0 = display current temp.) (1 = display defrost start temp.) (2 = display message dEF)		0	2	2
d3	Maximum time of message added at end of defrost		0 min.	5 min.	99 min.
d4	Final defrost temperature by sensor 2 (if programmed in P4) In 2 relays versions operates if P6 = 0	°C/°F	-50	8	126
d5	Defrost start-up on equipment switch-on: (0 = first defrost according d0) (1 = first defrost according d6)		0	0	1
d6	Defrost start-up delay on equipment switch-on if d5=1		0 min.	0 min.	99 min.
d7	Defrost type: 0 = Electric heat 1 = Hot gas bypass Defrost by air in 2 relays versions P6 and F3 must be programmed		0	0	1
d8	Time calculation between defrost periods: (0 = Total real time) (1 = Compressor operation sum)		0	0	1
d9	Drip time, compressor stop and FAN/R2 relay off when defrost ends In 2 relays versions R2 operates in any case of P6		0 min.	1 min.	99 min.
FAn	Level 2	FANS (evaporator) control parameters			
	Level 3	Values	Min.	Def.	Max.
F0	Fan stop temp. by sensor 2 (if programmed in P4)	°C/°F	-50	4	126
F1	Sensor 2 (F0) differential for switching the FAN/R2 relay A1 and A2 differential 2 relays versions R2 operates if P6 = 1 and P4 = 2/3	°C/°F	1	2	50
F2	Stop fans if compressor stops? (0 = no) (1 = yes) In 2 relays versions R2 operates if P6 = 1		0	0	1
F3	Fan status during defrost (0 = stopped) (1 = running)		0	0	1
F4	Start-up delay after defrost (operates if it is higher than d9)		0 min.	3 min.	99 min.
F5	Stop fan if door opens? (0 = no) (1 = yes) (door if P9 = 1)		0	0	1
AL	Level 2	ALARMS (Visual, acoustic or relay) control parameters			
	Level 3	Values	Min.	Def.	Max.
A1	Maximum, temp. above the Set Point in sensor 1	°C/°F	0	0	126
A2	Minimum, temp. below the Set Point in sensor 1	°C/°F	0	0	126
A3	Start-up temperature alarm delay (if programmed in A1, A2)		0	0	120 min.
A4	Temp. alarm delay from end of defrost		0	0	99 min.
A5	Temp. alarm delay from the temperature at which they operate		0	30 min.	99 min.
A6	Temp. alarm delay from digital input disable (door if P9 = 1)		0	0	126 min.
A7	Temp. alarm delay from digital input enable (door if P9 = 1)		0	0	126 min.
A8	Alarms if defrost ends by maximum time: (0 = no) (1 = yes)		0	0	1
A9	Relay 4 alarm polarity configuration: (0 = with alarm relay ON) (1 = with alarm relay OFF)		0	0	1
CnF	Level 2	GENERAL STATUS parameters			
	Level 3	Values	Min.	Def.	Max.
P1	Delay for all function on power supply switch on		0 min.	0 min.	99 min.
P2	Programmed parameter block: (0 = Unblocked, inf. AKOTIM disabled) (2 = Unblocked, inf. AKOTIM enabled) (1 = Blocked, inf. AKOTIM disabled) (3 = Blocked, inf. AKOTIM enabled)		0	0	3
P3	Initial parameters: (1=yes, configure to "Def" and exit programming if P2 = 0)		0	0	1
P4	Connected sensors: (1 = Sensor 1) (2 = Sensor 1 +Sensor 2) (3 = Sensor 1 +Sensor 2 +Sensor 3) (4 = Sensor 1 +Sensor 3)		1	1	4
P5	Address for equipment with communication		0	0	126
P6	Relay 2 (R2) function in 2 relays versions: (0 = defrost by electric heat) (1 = fan control)		0	0	1
P7	Temperature display mode: (0 = Whole in °C) (1 = One decimal in °C) (2 = Whole in °F) (3 = One decimal in °F)		0	0	3
P8	Displayed sensor: (1 = Sensor 1) (2 = Sensor 2) (3 = Sensor 3)		1	1	3
P9	Digital input configuration: (0 = disabled) (1 = door) (2 = external alarm)		0	0	2
P10	Contact with open door or enabled alarm: (0 = open) (1 = closed)		0	0	1
P11	Transfer parameters: (0 = disabled) (1 = send) (2 = receive)		0	0	2
P12	Program version (information)				
rTC	Level 2	REAL TIME CLOCK parameters			
	Level 3	Values	Min.	Def.	Max.
d10	1st defrost hour start time		0	off	23
d11	2nd defrost hour start time		0	off	23
d12	3rd defrost hour start time		0	off	23
d13	4th defrost hour start time		0	off	23
d14	5th defrost hour start time		0	off	23
d15	6th defrost hour start time		0	off	23
r1	Clock configuration, Hour		0	XX	23
r2	Clock configuration, Minute		0	XX	59
tid	Level 2	AKOTIM information parameters			
	Level 3	Values	Min.	Def.	Max.
L1	Maximum temperature admitted in refrigeration period	°C/°F	C3	126	126
L2	Minimum temperature admitted in refrigeration period	°C/°F	-50	-50	C2
L3	Maximum partial time admitted outside rating conditions		0 min.	0 min.	99 min.
L4	Maximum time admitted to recover temperature after defrosting		0 min.	0 min.	99 min.
L5	Access password for AKOTIM parameters and information		0	0	126
EP	Programming or level exit				
	MESSAGES				
dEF	Fixed - Indicates defrost is being carried out. In order to display "dEF" when defrosting, it is essential that parameter d2 is set to option 2.				
E1	Fixed - Sensor 1 failure (open circuit, crossed, temp.> 110°C or temp.<-55°C)				
E2	Flashing with temperature - Sensor 2 failure (open circuit, crossed, temp.> 110°C or temp.<-55°C)				
E3	Flashing with temperature - Sensor 3 failure (open circuit, crossed, temp.> 110°C or temp.<-55°C)				
E5	Fixed - Incorrect sensor configuration (see P4, P8)				
EE	Fixed - Memory failure				
UP	Flashing with temperature - Temperature outside AKOTIM rating conditions and increasing.				
dn	Flashing with temperature - Temperature outside AKOTIM rating conditions and decreasing.				

NOTE: When the time parameters are modified, the new values are applied once the current cycle is completed. In order for it to have an immediate effect, switch the controller off and then on again.