

AT1-5 INSTRUCTIONS FOR USE

Thank you for having chosen a LAE electronic product. Before installing the instrument, please read these instructions carefully to ensure maximum performance and safety.

DESCRIPTION



Fig.1 — Front panel

- | | | | |
|--|-----------------------------------|--|--------------------------------------|
| | Info / Setpoint button. | | Increase / manual activation button. |
| | Manual defrost / Decrease button. | | Exit / Stand-by button. |

INDICATIONS

- Thermostat output
- Auxiliary output
- Alarm

INSTALLATION

- Insert the controller through a hole measuring 71x29 mm.
- Make sure that electrical connections comply with the paragraph "wiring diagrams". To reduce the effects of electromagnetic disturbance, keep the sensor and signal cables well separate from the power wires.
- Fix the controller to the panel by means of the suitable clips, by pressingly gently; if fitted, check that the rubber gasket adheres to the panel perfectly, in order to prevent debris and moisture infiltration to the back of the instrument.
- Place the probe T1 inside the room in a point that truly represents the temperature of the stored product.
- Place the probe T2 where there is the maximum formation of frost.

OPERATION

DISPLAY

During normal operation, the display shows either the temperature measured or one of the following indications:

DEF	Defrost in progress	HI	Room high temperature alarm
REC	Recovery after defrost	LO	Room low temperature alarm
OFF	Controller in stand-by	E1	Probe T1 failure
CL	Condenser clean warning	E2	Probe T2 failure
DO	Door open alarm		

INFO MENU

The information available in this menu is:

T1	Instant probe 1 temperature	TLO	Minimum probe 1 temperature recorded
T2	Instant probe 2 temperature	CND	Compressor working weeks
THI	Maximum probe 1 temperature recorded	LOC	Keypad state lock

Access to menu and information displayed.

- Press and immediately release button .
- With button or select the data to be displayed.
- Press button to display value.
- To exit from the menu, press button or wait for 10 seconds.

Reset of THI, TLO, CND recordings

- With button or select the data to be reset.
- Display the value with button .
- While keeping button pressed, use button .

SETPOINT (display and modification of desired temperature value)

- Press button for at least half second, to display the setpoint value.
- By keeping button pressed, use button or to set the desired value (adjustment is within the minimum **SPL** and the maximum **SPH** limit).
- When button is released, the new value is stored.

STAND-BY

Button , when pressed for 3 seconds, allows the controller to be put on a standby or output control to be resumed (with **SB**=YES only).

KEYPAD LOCK

The keypad lock avoids undesired, potentially dangerous operations, which might be attempted when the controllers is operating in a public place. In the INFO menu, set parameter **LOC**=YES to inhibit all functions of the buttons. To resume normal operation of keypad, adjust setting so that **LOC**=NO.

DEFROST

Timed defrost. Defrosting starts automatically when necessary time has elapsed to obtain the defrosting frequency set with **DFR**. For example, with **DFR**=4 defrosting occurs once every 6 hours. The internal timer is set to zero when power is applied to the controller and at each subsequent defrost start. When the controller is put on a standby, the accumulated time count is "frozen" (is not incremented).

Manual defrost. Defrosting may also be induced manually by keeping the button pressed for 2 seconds.

Defrost type. Once defrost has started, Compressor and Defrost outputs are controlled according to the parameters **DTY** and **OAU**. The AUX output is associated to defrost function with **OAU**=DEF exclusively.

Defrost termination. Defrost lasts as long as time **DTO** but, if the evaporator probe has been enabled (**T2**=YES) and temperature **DLI** is achieved before this time elapses, defrost will be terminated in advance.

Caution: if C-H=HEA all defrost functions are inhibited; if DFR=0 the timed defrost function is excluded; during defrost, the high temperature alarm is inhibited.

CONFIGURATION PARAMETERS

- The setup menu is accessed by pressing button + for 5 seconds.
- With button or select the parameter to be modified.
- Press button to display the value.
- By keeping button pressed, use button or to set the desired value.
- When button is released, the newly programmed value is stored and the following parameter is displayed.
- To exit from the setup, press button or wait for 30 seconds.

PAR	RANGE	DESCRIPTION
SCL	1°C; 2°C; °F	Readout scale. 1°C (only with INP =SN4): measuring range -50/-9.9 ... 19.9/80°C 2°C: measuring range -50 ... 120°C °F: measuring range -55 ... 240°F Caution: upon changing the SCL value, it is then <u>absolutely</u> necessary to reconfigure the parameters relevant to the absolute and relative temperatures (SPL , SPH , SP , ALA , AHA , etc..)
SPL	-50..SPH	Minimum limit for SP setting
SPH	SPL.120°	Maximum limit for SP setting
SP	SPL... SPH	Setpoint (value to be maintained in the room).
C-H	REF; HEA	Refrigerating (REF) or Heating (HEA) control mode
HYS	1...10°	OFF/ON thermostat differential Refrigerating control (C-H=REF) Heating control (C-H=HEA)
CRT	0...30min	Compressor rest time. The output is switched on again after CRT minutes have elapsed since the previous switchover. We recommend to set CRT =03 with HYS <2.0°.
CT1	0...30min	Thermostat output run when probe T1 is faulty. With CT1 =0 the output will always remain OFF.
CT2	0...30min	Thermostat output stop when probe T1 is faulty. With CT2 =0 and CT1 >0 the output will always be ON. Example: CT1 =4, CT2 =6: In case of probe T1 failure, the compressor will cycle 4 minutes ON and 6 minutes OFF.
CSD	0...30min	Compressor stop delay after the door has been opened (active only if DS =YES).
DFR	0...24(1/24h)	Defrost frequency expressed in cycles/24 hours.
DLI	-50...120°	Defrost end temperature.
DTO	1...120min	Maximum defrost duration.
DTY	OFF; ELE; GAS	Defrost type OFF: off cycle defrost (Compressor and Heater OFF). ELE: electric defrost* (Compressor OFF and Heater ON). GAS: hot gas defrost* (Compressor and Heater ON). * The defrost output is active if only OAU =DEF.
DDY	0...60min	Display during defrost. If DDY =0 during defrost the temperature continues to be displayed. If DDY >0, during defrost the display shows DEF, when defrost is over REC is displayed during DDY minutes.
ATM	NON; ABS; REL	Alarm threshold management. NON: all temperature alarms are inhibited (the following parameter will be ADO). ABS: the values programmed in ALA and AHA represent the real alarm thresholds. REL: the values programmed in ALR and AHR are alarm differentials referred to SP and SP+HY . Temperature alarm with relative thresholds, refrigerating control (ATM =REL, C-H =REF). Temperature alarm with relative thresholds, heating control (ATM =REL, C-H =HEA).
ALA	-50... 120°	Low temperature alarm threshold.
AHA	-50... 120°	High temperature alarm threshold.
ALR	-12... 0°	Low temperature alarm differential. With ALR =0 the low temperature alarm is excluded.
AHR	0... 12°	High temperature alarm differential. With AHR =0 the high temperature alarm is excluded.
ATD	0... 120min	Delay before alarm temperature warning.
ADO	0... 30min	Delay before door open alarm warning.
ACC	0...52 weeks	Condenser periodic cleaning. When the compressor operation time, expressed in weeks, matches the ACC value programmed, "CL" flashes in the display. With ACC =0 the condenser cleaning warning is disabled.
SB	NO/YES	Stand-by button enabling .
DS	NO/YES	Door switch input enabling (closed when door is closed).
OAU	NON; 0-1; DEF; LGT; ALR;	AUX output operation NON: output disabled (always off). 0-1: the relay contacts follow the on/standby state of controller. DEF: output programmed for defrost control. LGT: output enabled for light control. ALR: contacts make when an alarm condition occurs.
INP	SN4; ST1	Temperature sensor selection. With INP = SN4, the probes must be the LAE models SN4.; with INP = ST1, the probes must be the LAE models ST1...

OS1	-12.5..12.5°C	Probe T1 offset.
T2	NO/YES	Probe T2 enabling (evaporator).
OS2	-12.5..12.5°C	Probe T2 offset.
TLD	1...30 min	Delay for minimum temperature (TLO) and maximum temperature (THI) logging.
SIM	0...100	Display slowdown.
ADR	1...255	AT1-5 address for PC communication.

WIRING DIAGRAM

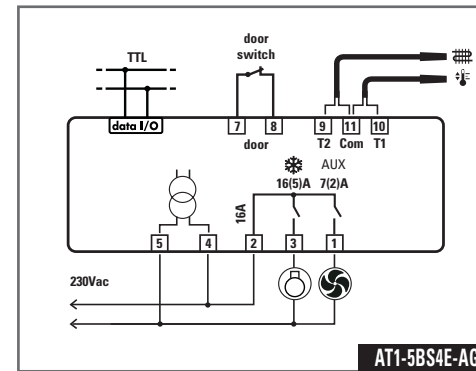

AT1-5BS4E-AG

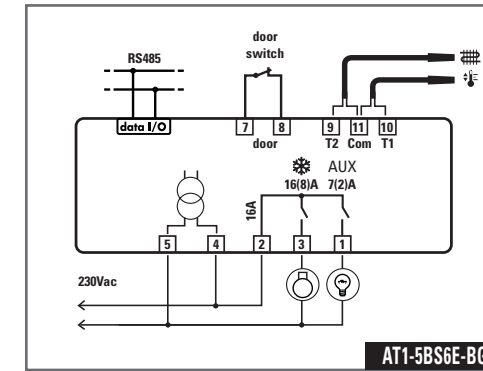

AT1-5BS6E-BG

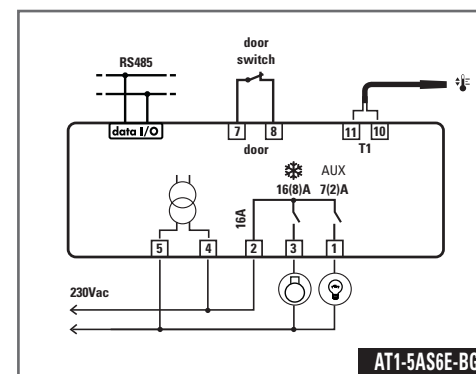

AT1-5AS6E-BG

TECHNICAL DATA

Power supply

AT1-5...E	230Vac±10%, 50/60Hz, 3W
AT1-5...U	115Vac±10%, 50/60Hz, 3W
AT1-5...D	12Vac±10%, 50/60Hz, 3W

Relay outputs

AT1-5. Q1 (2)...	compressor 12(4)A
AT1-5. S1 (2)...	compressor 16(4)A
AT1-5. Q3 (4)...	compressor 12(5)A
AT1-5. S3 (4)...	compressor 16(5)A
AT1-5. Q5 (6)...	compressor 12(8)A
AT1-5. S5 (6)...	compressor 16(8)A
Auxiliary loads 7(2)A 240vac	

AT1-5.**Q**... maximum total current 12A
AT1-5.**S**... maximum total current 16A

Inputs

NTC 10KΩ@25°C,	LAE part No. SN4...
PTC 1000Ω@25°C,	LAE part No. ST1...

Measuring Range

-50...120°C,	-55...240°F
-50/-9.9 ... 19.9/80°C (with NTC10K only)	

Measuring accuracy

<0.5°C within the measurement range

Operating conditions

-10 ... +50°C; 15%...80% r.H.

CE – UL (Approvals and Reference Norms)

EN60730-1; EN60730-2-9;
EN55022 (Class B);
EN50082-1
UL 60730-1A

Front protection

IP55



VIA PADOVA, 25
31046 ODERZO /TV /ITALY
TEL. +39 - 0422 815320
FAX +39 - 0422 814073
www.lae-electronic.com
E-mail: sales@lae-electronic.com