

DATI TECNICI
TECHNICAL DATA

ETICHETTA
LABEL

IMOTT WW/YY

TR 0/+87 °C TYPE TR2 9335

N.C.C-1 16(6)A/250V~ T85
 N.O.C-2 6(4)A/250V~ T85

15(2,5)A/250V~
 0497 ISPEL TS/017/10
 Cat. IV DINR1211

541307/C

AZIONE TIPO ACTION TYPE	1B (EN 60730-1)
INSTALLAZIONE TIPO METHOD OF MOUNTING	A PANNELLO PANEL MOUNTING
TENSIONE IMPULSIVA NOMINALE RATED IMPULSE VOLTAGE	2,5 kV
INTERVALLO DI REGOLAZIONE CONTROL RANGE	0 / 87±3 °C
DIFFERENZIALE SWITCHING DIFFERENTIAL	Δt 4±1 K
MAX. TEMPERATURA TESTA TERMOSTATO MAX. SWITCHING HEAD TEMPERATURE	T 85 °C
MAX TEMPERATURA BULBO MAX BULB TEMPERATURE	130 °C
PORTATA CONTATTI CONTACTS RATING	NC 6FLA - 16A N.I. 250V~ NO 4FLA - 6A N.I. 250V~
EFFETTO TEMPERATURA AMBIENTE AMBIENT TEMPERATURE EFFECT	- 0,20°C/°C (*)
RAGGIO MIN. CURVATURA CAPILLARE MIN. CAPILLARY BENDING RADIUS	5 mm.
FLUIDO CONTROLLATO CONTROLLED MEDIUM	ACQUA , OLIO WATER , OIL
GRADO DI INQUINAMENTO POLLUTION SITUATION	2 (EN 60730-1)

SCHEMA ELETTRICO
WIRING DIAGRAM

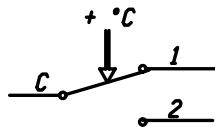

VALORI D'INTERVENTO CON TERMOSTATO A TEMPERATURA DI 20 °C
SWITCHING POINT WITH THERMOSTAT AT TEMPERATURE = 20 °C
 (*) MAX. VARIAZIONE DEL PUNTO DI INTERVENTO IN RAPPORTO ALLA
 VARIAZIONE DAL VALORE DI RIFERIMENTO DELLA TEMPERATURA AMBIENTE
 (*) MAX. CHANGE IN SWITCHING POINT REFERRED TO CHANGE
 FROM REFERENCE OF AMBIENT TEMPERATURE

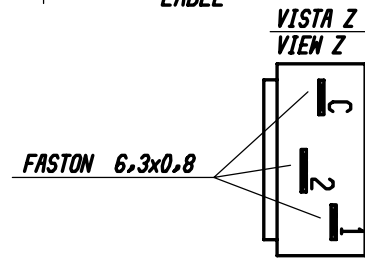
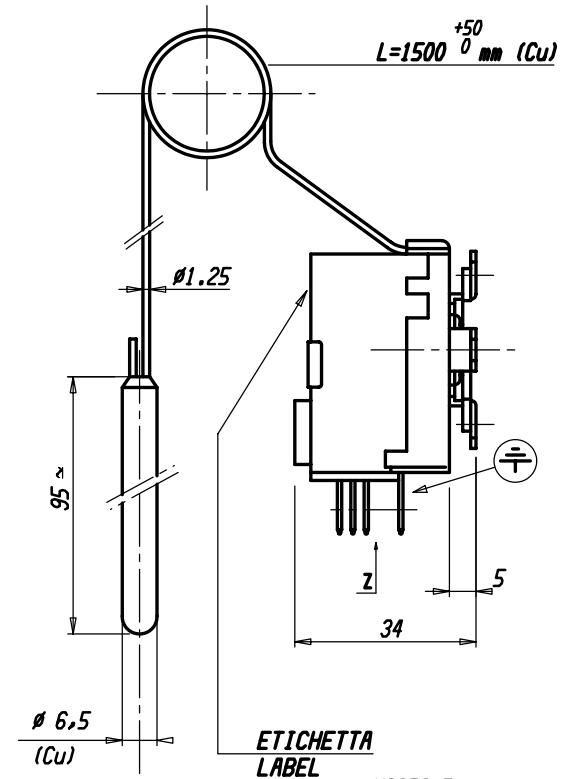
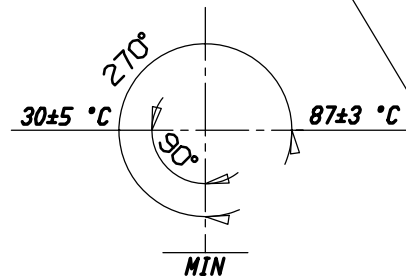
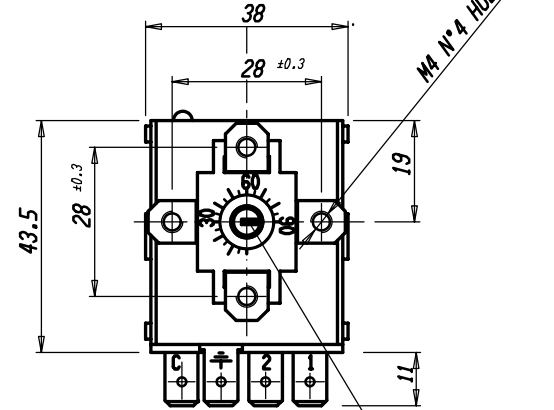

Pos.	Codice	Denominazione	N. Pezzi	Note																							
Materiale																											
Treatment																											
	Peso grezzo	Quote senza indicazione di tolleranza: precisione gruppo	B	Lunghezza lato minore																							
	Peso finito	<table style="font-size: x-small;"> <tr> <td>da 0</td><td>da 6</td><td>da 30</td><td>da 120</td><td>da 315</td><td>da 1000</td><td>OLTRE</td> </tr> <tr> <td>a < 6</td><td>a < 30</td><td>a < 120</td><td>a < 315</td><td>a < 1000</td><td>a ≤ 2000</td><td>2000</td> </tr> </table>	da 0	da 6	da 30	da 120	da 315	da 1000	OLTRE	a < 6	a < 30	a < 120	a < 315	a < 1000	a ≤ 2000	2000	da 0	da 10	da 50	OLTRE							
da 0	da 6	da 30	da 120	da 315	da 1000	OLTRE																					
a < 6	a < 30	a < 120	a < 315	a < 1000	a ≤ 2000	2000																					
	Progetto N°	<table style="font-size: x-small;"> <tr> <td>A ±0.05</td><td>±0.1</td><td>±0.15</td><td>±0.2</td><td>±0.3</td><td>±0.5</td><td>-</td> </tr> <tr> <td>B ±0.1</td><td>±0.2</td><td>±0.3</td><td>±0.5</td><td>±0.8</td><td>±1.2</td><td>±2</td> </tr> <tr> <td>C ±0.2</td><td>±0.5</td><td>±0.8</td><td>±1.2</td><td>±2</td><td>±3</td><td>±4</td> </tr> </table>	A ±0.05	±0.1	±0.15	±0.2	±0.3	±0.5	-	B ±0.1	±0.2	±0.3	±0.5	±0.8	±1.2	±2	C ±0.2	±0.5	±0.8	±1.2	±2	±3	±4	±1*	±30'	±20'	±10'
A ±0.05	±0.1	±0.15	±0.2	±0.3	±0.5	-																					
B ±0.1	±0.2	±0.3	±0.5	±0.8	±1.2	±2																					
C ±0.2	±0.5	±0.8	±1.2	±2	±3	±4																					
Disegn. A. CALDERONI		24/01/11	Verif. M. CAPITANIO	24/01/11																							
Scala		1:1	Sost. // PARI CODICE																								
Disegn./Codice		541307/C		IMOTT																							
Denominaz.		TERMOSTATO TR2 / ADJUSTABLE THERMOSTAT MOD. TR2																									
Mat. Mod. num.		A3																									
Il presente disegno non può essere riprodotto, copiato o comunicato a terzi senza la nostra autorizzazione, come a termine di legge sui diritti d'autore																											