

ELECTRONIC MODULAR FLAKERS AND SUPERFLAKERS

F 100 C
F 100
F 120
F 200
SF 300
SF 500
SF 1000

Gas R134a - R 404a



UR SYSTEMS COMPLY WITH EEC DIRECTIVE 73/23 - 89/336

lcematic®

SERVICE MANUAL

Cod. 71503382/0-GB - Rev. 001 - 01/2001

TABLE OF CONTENTS

Specifications F 100C	pagina	2
Specifications F 100		4
Specifications F 120		6
Specifications F200		8
Specifications SF 300		10
Specifications SF 500		12
Specifications SF 1000		14

GENERAL INFORMATION AND INSTALLATION

Introduction		16
Unpacking and Inspection - Ice maker		16
Unpacking and Inspection - Storage bin		16
Location and levelling		17
Electrical connections		18
Water supply and drain connections		18
Final check list		19
Installation practice		19

OPERATING INSTRUCTIONS

Start up		20
Operational checks		22

PRINCIPLE OF OPERATION (How it works)

Water circuit		25
Refrigerant circuit		26
Mechanical system		28
Operating characteristics		29
Operating pressures		30
Components description		

ADJUSTMENT, REMOVAL AND REPLACEMENT PROCEDURES

Adjustment of the evaporator water level		34
Replacement of evaporator temperature sensor		34
Replacement of condenser temperature sensor		34
Replacement of ice level light control		34
Replacement of P.C. Board		35
Replacement of the ice spout		35
Replacement of the auger, water seal, bearings and coupling		35
Replacement of the gear motor assy		36
Replacement of fan motor		36
Replacement of drier		36
Replacement of the freezing cylinder		37
Replacement of air cooled condenser		37
Replacement of water cooled condenser		37
Replacement of water regulating valve (water cooled models)		38
Replacement of compressor		38
Wiring diagram		39
Service diagnosis		43

MAINTENANCE AND CLEANING INSTRUCTIONS

General		45
Icemaker		45
Cleaning instructions of water system		45

SPECIFICATIONS

**ELECTRONIC MODULAR FLAKER
MODEL F 100C (R 134a)**

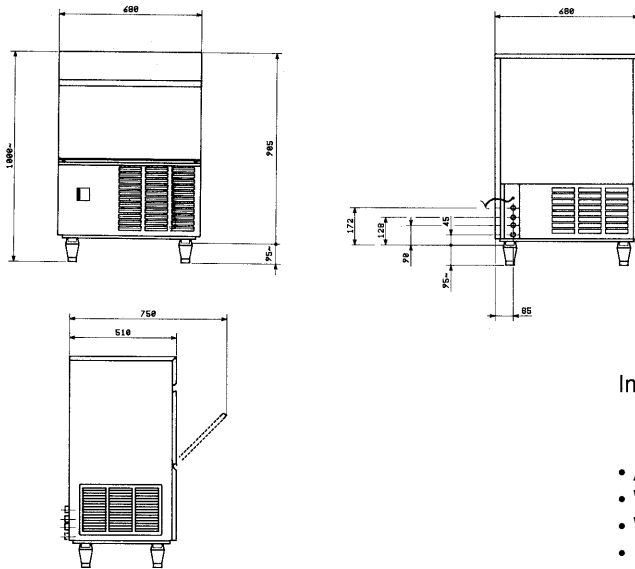

Important operating requirements:

	MIN	MAX
• Air temperature	10°C (50°F)	40°C (100°F)
• Water temperature	5°C (40°F)	40°C (100°F)
• Water pressure	1 bar (14 psi)	5 bars (70 psi)
• Electr. voltage variations from voltage rating specified on nameplate	-10%	+6%

ice making capacity

KG /24 H

84	90	93	95
82	88	91	93
77	82	85	87
74	78	80	82
32	21	15	10

F 100C W

WATER COOLED

10
21
32
38

89	92	94	96
86	89	91	92
72	74	76	78
62	64	66	67
32	21	15	10

F 100C A

AIR COOLED



NOTE. The daily ice-making capacity is directly related to the condenser air inlet temperature, water temperature and age of the machine.
To keep your **FLAKER** at peak performance levels, periodic maintenance checks must be carried out as indicated on page 43 of this manual.

SPECIFICATIONS

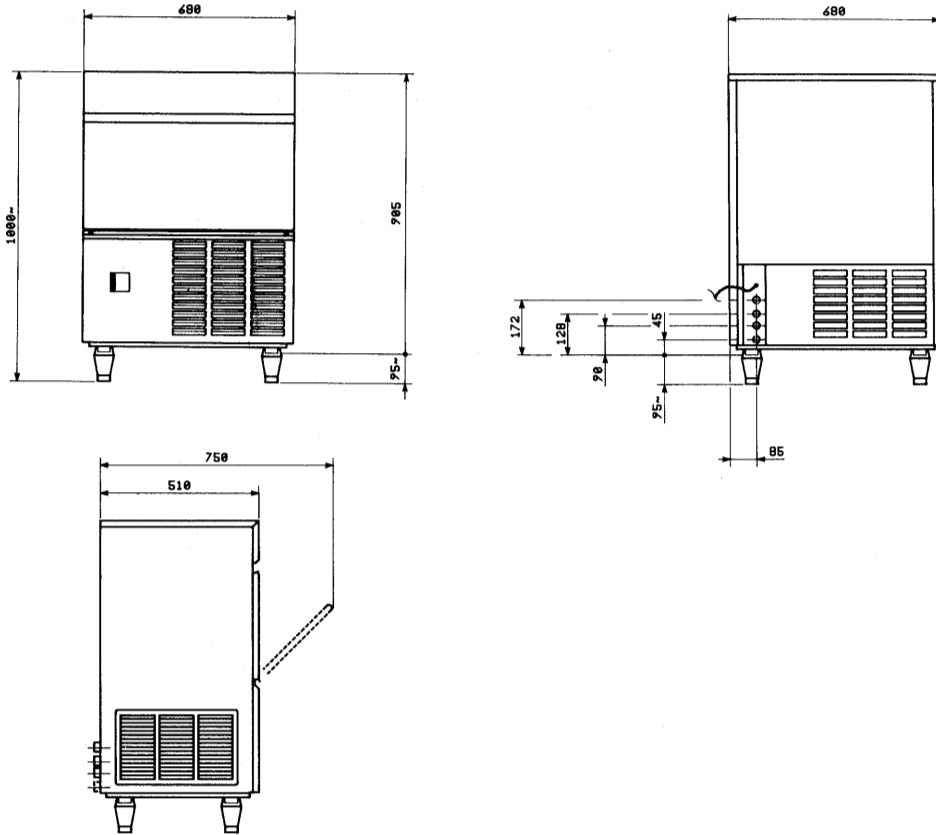

Dimensions:
 HEIGHT (less legs) 905 mm.
 HEIGHT (with legs) 1000 mm.
 WIDTH 680 mm.
 DEPTH 510 mm.
 WEIGHT 64 Kg.

F 100C - MACHINE SPECIFICATIONS

Model	Cond. unit	Finish	Comp. HP	Water req. lt/24 HR		
F 100C INOX F 100C W INOX	Air Water	S. Steel	1/4	96 430*		
Basic electr.	Amps	Start Amps	Watts	Electric power cons. Kwh per 24 HR	Nr. of wires	Amps fuse
220/50/1	2,2	9,6	370	8,8	3 x 1 mm ²	10

* A 15°C water temperature

SPECIFICATIONS

**ELECTRONIC MODULAR FLAKER
MODEL F 100 (R 134a)**

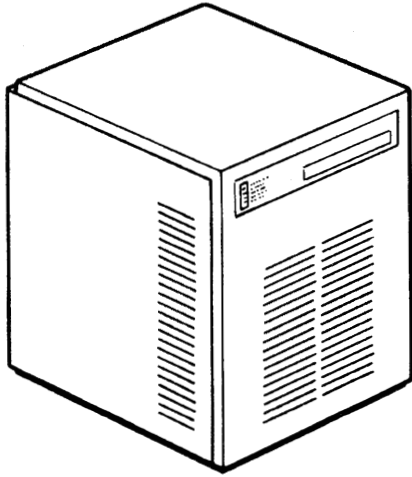

Important operating requirements:

	MIN	MAX
• Air temperature	10°C (50°F)	40°C (100°F)
• Water temperature	5°C (40°F)	40°C (100°F)
• Water pressure	1 bar (14 psi)	5 bars (70 psi)
• Electr. voltage variations from voltage rating specified on nameplate	-10%	+6%

ice making capacity

KG/24 H

83	89	92	95
76	82	85	88
72	78	81	84
70	76	79	82
32	21	15	10

F 100 W
RAFFR. ACQUA
WATER COOLED

10
21
32
38

78	84	87	90
76	82	85	88
64	70	73	76
60	66	69	72
32	21	15	10

F 100 A
RAFFR. ARIA
AIR COOLED

°C TEMPERATURA AMBIENTE
AMBIENT TEMPERATURE

°C TEMPERATURA ACQUA
WATER TEMPERATURE

NOTE. The daily ice-making capacity is directly related to the condenser air inlet temperature, water temperature and age of the machine.
To keep your **FLAKER** at peak performance levels, periodic maintenance checks must be carried out as indicated on page 43 of this manual.

SPECIFICATIONS

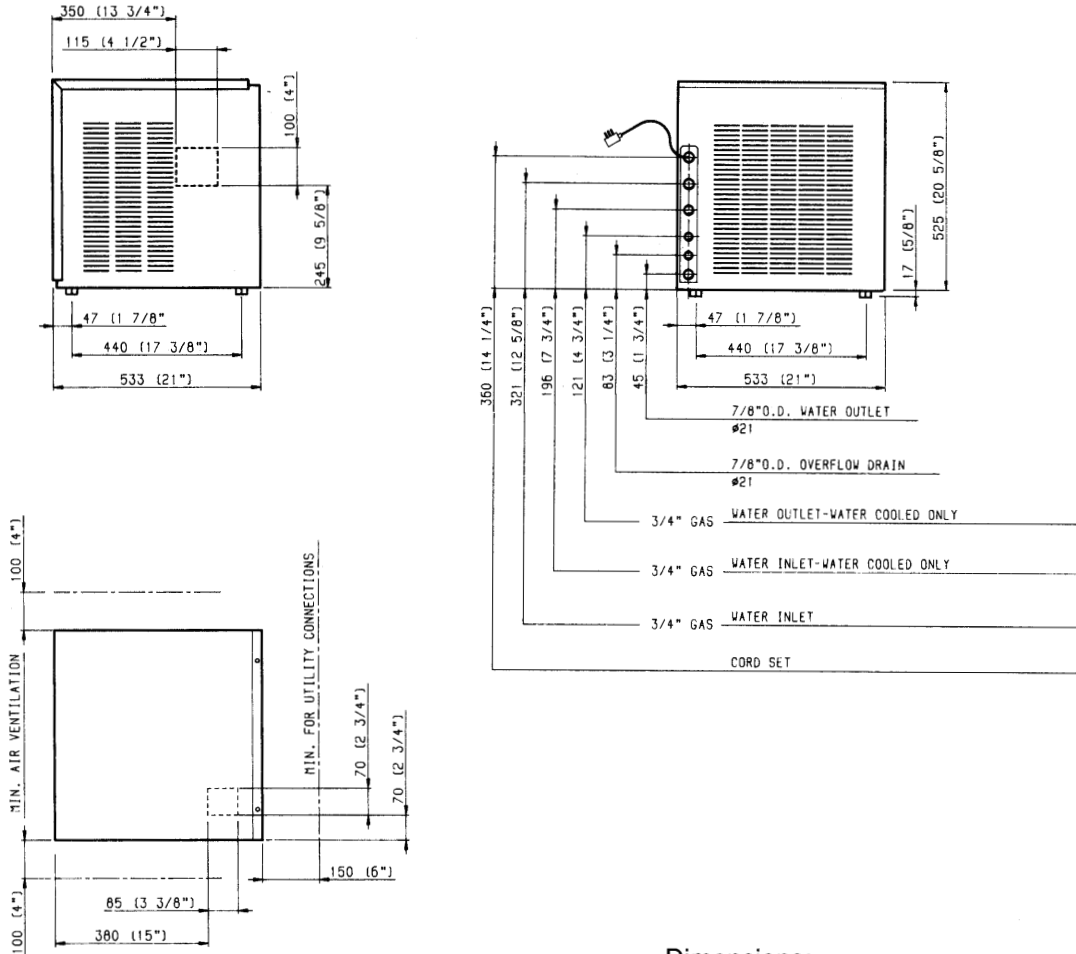

Dimensions:
 HEIGHT (less legs) 525 mm.
 HEIGHT (with legs) 542 mm.
 WIDTH 533 mm.
 DEPTH 533 mm.
 WEIGHT 49 Kg.

F 100 - MACHINE SPECIFICATIONS

Model	Cond. unit	Finish	Comp. HP	Water req. l/24 HR		
F 100 INOX F 100 W INOX	Air Water	S. Steel	1/5	96 430*		
Basic electr.	Amps	Start Amps	Watts	Electric power cons. Kwh per 24 HR	Nr. of wires	Amps fuse
220/50/1	2,1	9,1	350	8,5	3 x 1 mm ²	6

* A 15°C water temperature

SPECIFICATIONS

**ELECTRONIC MODULAR FLAKER
MODEL F 120 (R 134a)**

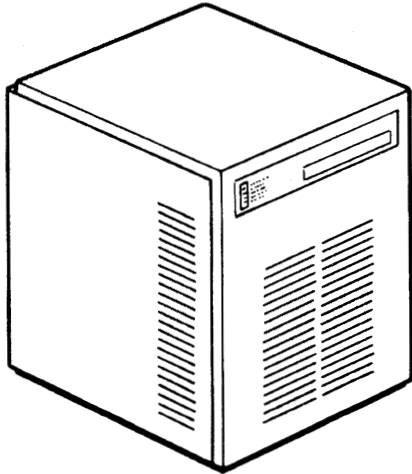

Important operating requirements:

	MIN	MAX
• Air temperature	10°C (50°F)	40°C (100°F)
• Water temperature	5°C (40°F)	40°C (100°F)
• Water pressure	1 bar (14 psi)	5 bars (70 psi)
• Electr. voltage variations from voltage rating specified on nameplate	-10%	+6%

ice making capacity

KG/24 H

104	112	116	120
94	102	106	110
89	97	101	105
87	95	99	103
32	21	15	10

F 100 W
RAFFR. ACQUA
WATER COOLED

10
21
32
38

104	112	116	120
98	106	110	114
87	95	99	103
80	88	92	96
32	21	15	10

F 100 A
RAFFR. ARIA
AIR COOLED

°C TEMPERATURA AMBIENTE
AMBIENT TEMPERATURE

°C TEMPERATURA ACQUA
WATER TEMPERATURE

NOTE. The daily ice-making capacity is directly related to the condenser air inlet temperature, water temperature and age of the machine.
To keep your **FLAKER** at peak performance levels, periodic maintenance checks must be carried out as indicated on page 43 of this manual.

SPECIFICATIONS

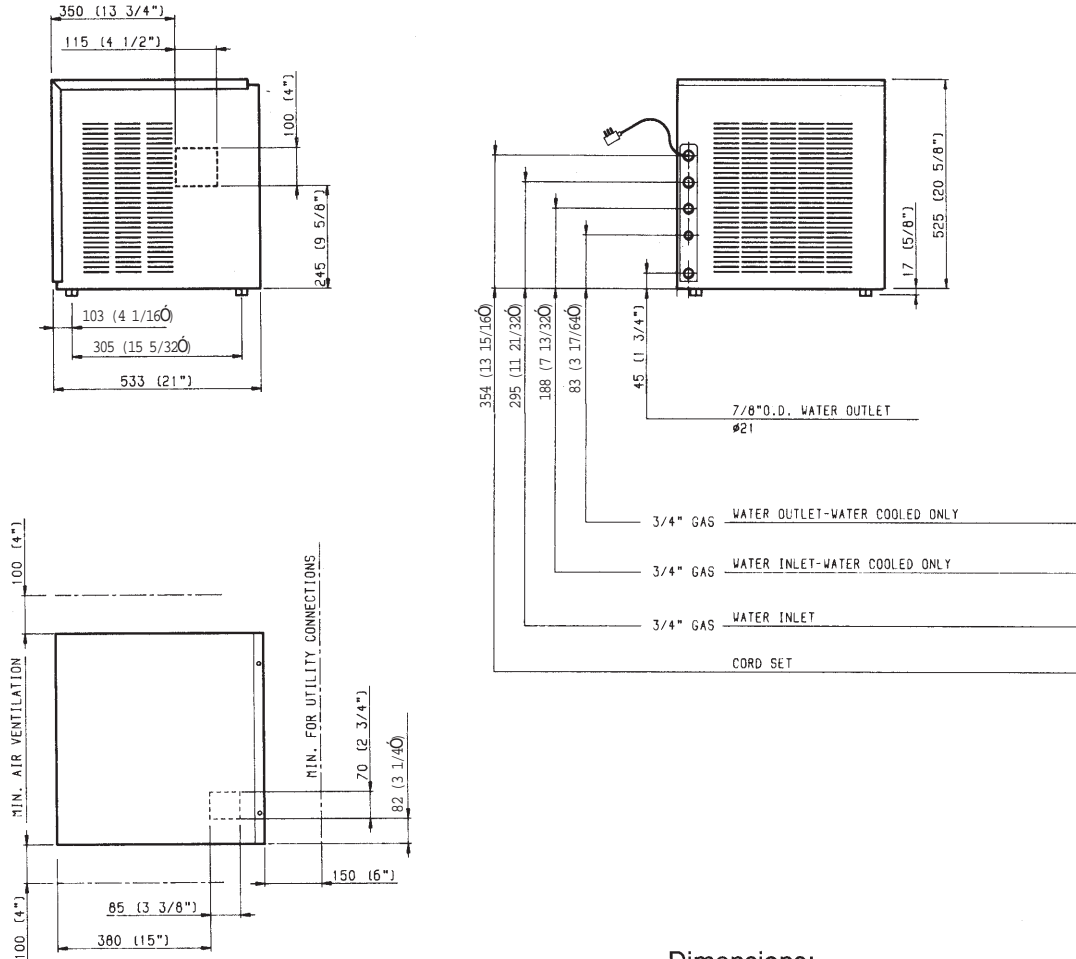

Dimensions:
 HEIGHT (less legs) 525 mm.
 HEIGHT (with legs) 542 mm.
 WIDTH 533 mm.
 DEPTH 533 mm.
 WEIGHT 40 Kg.

F 120 - MACHINE SPECIFICATIONS

Model		Cond. unit		Finish		Comp. HP		Water req. lt/24 HR	
F 120 INOX F 120 W INOX		Air Water		S. Steel		3/8		110	
Basic electr.	Amps	Start Amps	Watts	Electric power cons. Kwh per 24 HR	Nr. of wires	Amps fuse			
220/50/1	3,2	17	500	11	3 x 1 mm ²	10			

* A 15°C water temperature

SPECIFICATIONS

**ELECTRONIC MODULAR FLAKER
MODEL F 200 (R 404a)**

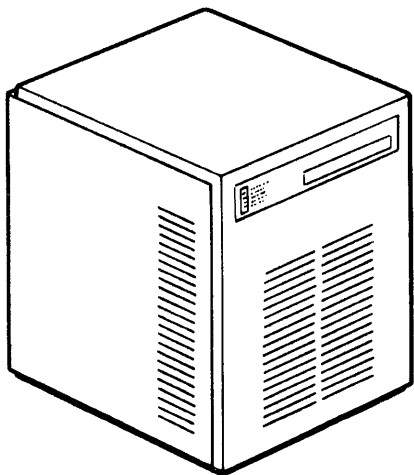

Important operating requirements:

	MIN	MAX
• Air temperature	10°C (50°F)	40°C (100°F)
• Water temperature	5°C (40°F)	40°C (100°F)
• Water pressure	1 bar (14 psi)	5 bars (70 psi)
• Electr. voltage variations from voltage rating specified on nameplate	-10%	+6%

ice making capacity

KG/24 H

154	172	182	190
152	170	180	188
150	168	178	186
146	164	173	182
32	21	15	10

F 200 W
RAFFR. ACQUA
WATER COOLED

10
21
32
38

168	184	192	200
160	176	184	192
135	153	163	172
125	143	153	162
32	21	15	10

F 200 A
RAFFR. ARIA
AIR COOLED

°C TEMPERATURA AMBIENTE
AMBIENT TEMPERATURE

°C TEMPERATURA ACQUA
WATER TEMPERATURE

NOTE. The daily ice-making capacity is directly related to the condenser air inlet temperature, water temperature and age of the machine.
To keep your **FLAKER** at peak performance levels, periodic maintenance checks must be carried out as indicated on page 43 of this manual.

SPECIFICATIONS

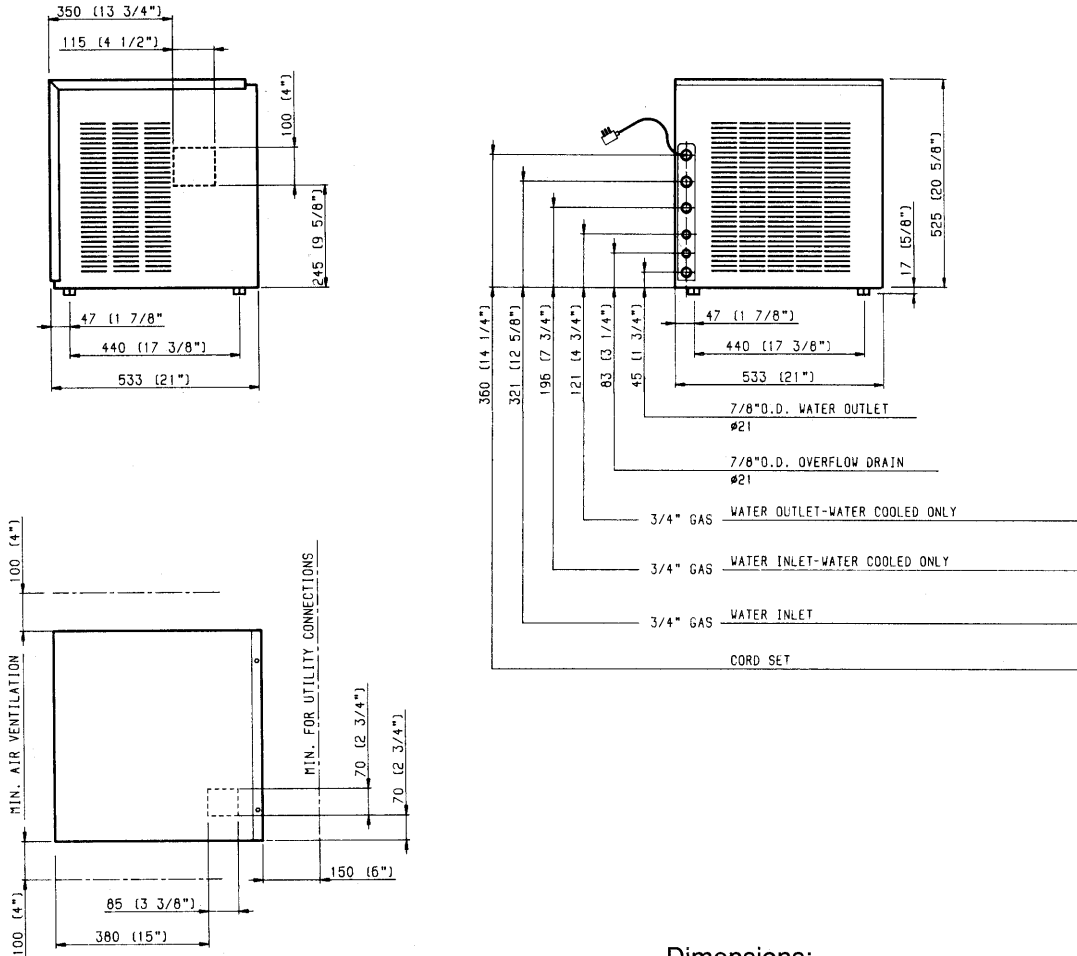

Dimensions:
 HEIGHT (less legs) 525 mm.
 HEIGHT (with legs) 542 mm.
 WIDTH 533 mm.
 DEPTH 533 mm.
 WEIGHT 49 Kg.

F 200 - MACHINE SPECIFICATIONS

Model		Cond. unit	Finish	Comp. HP	Water req. l/24 HR	
F 200 INOX F 200 W INOX		Air Water	S. Steel	1/2	200 850*	
Basic electr.	Amps	Start Amps	Watts	Electric power cons. Kwh per 24 HR	Nr. of wires	Amps fuse
220/50/1	3.4	15.8	670	16	3 x 1 mm ²	10

* A 15°C water temperature

SPECIFICATIONS

**ELECTRONIC MODULAR SUPERFLAKER
MODEL SF 300 (R 404a)**

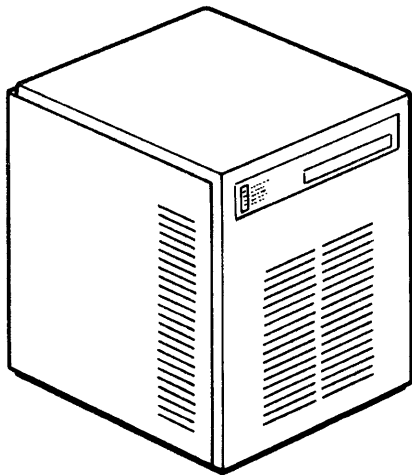

Important operating requirements:

	MIN	MAX
• Air temperature	10°C (50°F)	40°C (100°F)
• Water temperature	5°C (40°F)	40°C (100°F)
• Water pressure	1 bar (14 psi)	5 bars (70 psi)
• Electr. voltage variations from voltage rating specified on nameplate	-10%	+6%

ice making capacity

KG/24 H

270	300	315	330
265	295	310	325
260	290	305	320
250	280	295	310
32	21	15	10

SF 300 W
RAFFR. ACQUA
WATER COOLED

10
21
32
38

260	290	305	320
255	285	300	315
210	240	255	270
190	220	235	250
32	21	15	10

SF 300 A
RAFFR. ARIA
AIR COOLED

°C TEMPERATURA AMBIENTE
AMBIENT TEMPERATURE

°C TEMPERATURA ACQUA
WATER TEMPERATURE

NOTE. The daily ice-making capacity is directly related to the condenser air inlet temperature, water temperature and age of the machine.
To keep your **FLAKER** at peak performance levels, periodic maintenance checks must be carried out as indicated on page 43 of this manual.

SPECIFICATIONS

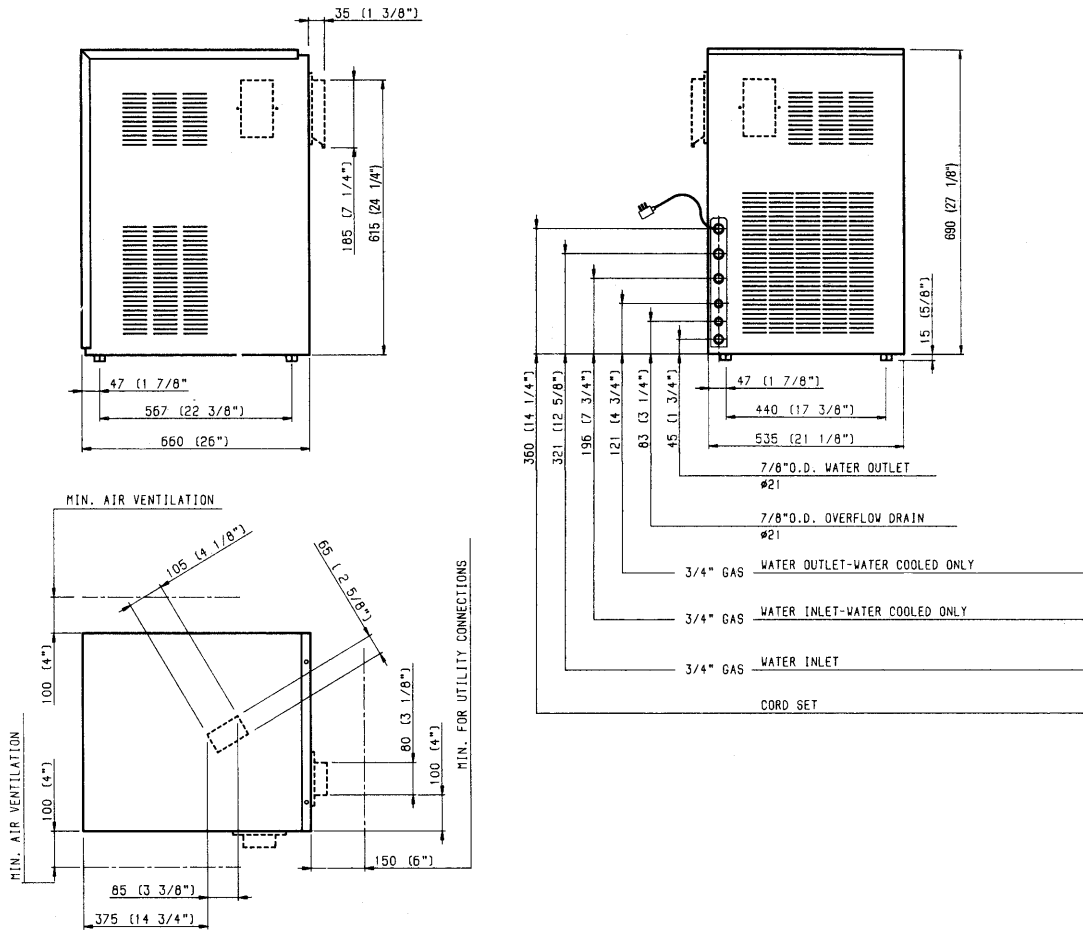

Dimensions:
 HEIGHT (less legs) 690 mm.
 HEIGHT (with legs) 705 mm.
 WIDTH 535 mm.
 DEPTH 660 mm.
 WEIGHT 77 Kg.

SF 300 - MACHINE SPECIFICATIONS

Model		Cond. unit		Finish		Comp. HP		Water req. l/24 HR	
SF 300 INOX SF 300 W INOX		Air Water		S. Steel		1		320 1700*	
Basic electr.	Amps	Start Amps	Watts	Electric power cons. Kwh per 24 HR	Nr. of wires	Amps fuse			
220/50/1	5.9	28	1080	26	3 x 1.5 mm ²	16			

* A 15°C water temperature

SPECIFICATIONS

**ELECTRONIC MODULAR SUPERFLAKER
MODEL SF 500 (R 404a)**

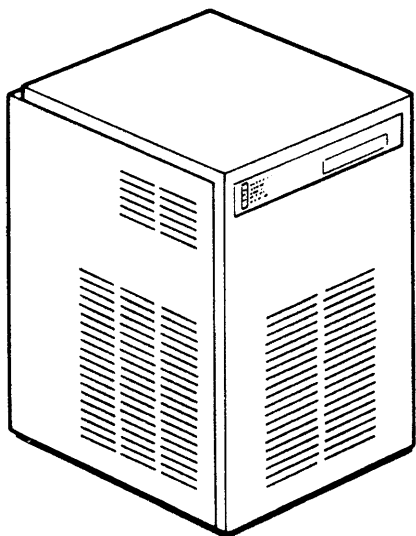

Limiti di funzionamento

	MIN.	MAX.
Temperatura ambiente	10°C	40°C
Temperatura acqua	5°C	40°C
Pressione acqua	1 bar	5 bar
Variazione rispetto alla tensione di targa	-10%	+6%

ice making capacity

KG/24 H

480	540	570	600
470	530	560	585
460	520	550	580
450	510	540	570
32	21	15	10

SF 500 W
RAFFR. ACQUA
WATER COOLED

10
21
32
38

440	520	560	600
420	500	540	580
360	440	480	520
330	410	450	490
32	21	15	10

SF 500 A
RAFFR. ARIA
AIR COOLED

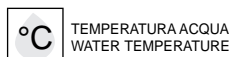

NOTE. The daily ice-making capacity is directly related to the condenser air inlet temperature, water temperature and age of the machine.
To keep your **FLAKER** at peak performance levels, periodic maintenance checks must be carried out as indicated on page 43 of this manual.

SPECIFICATIONS

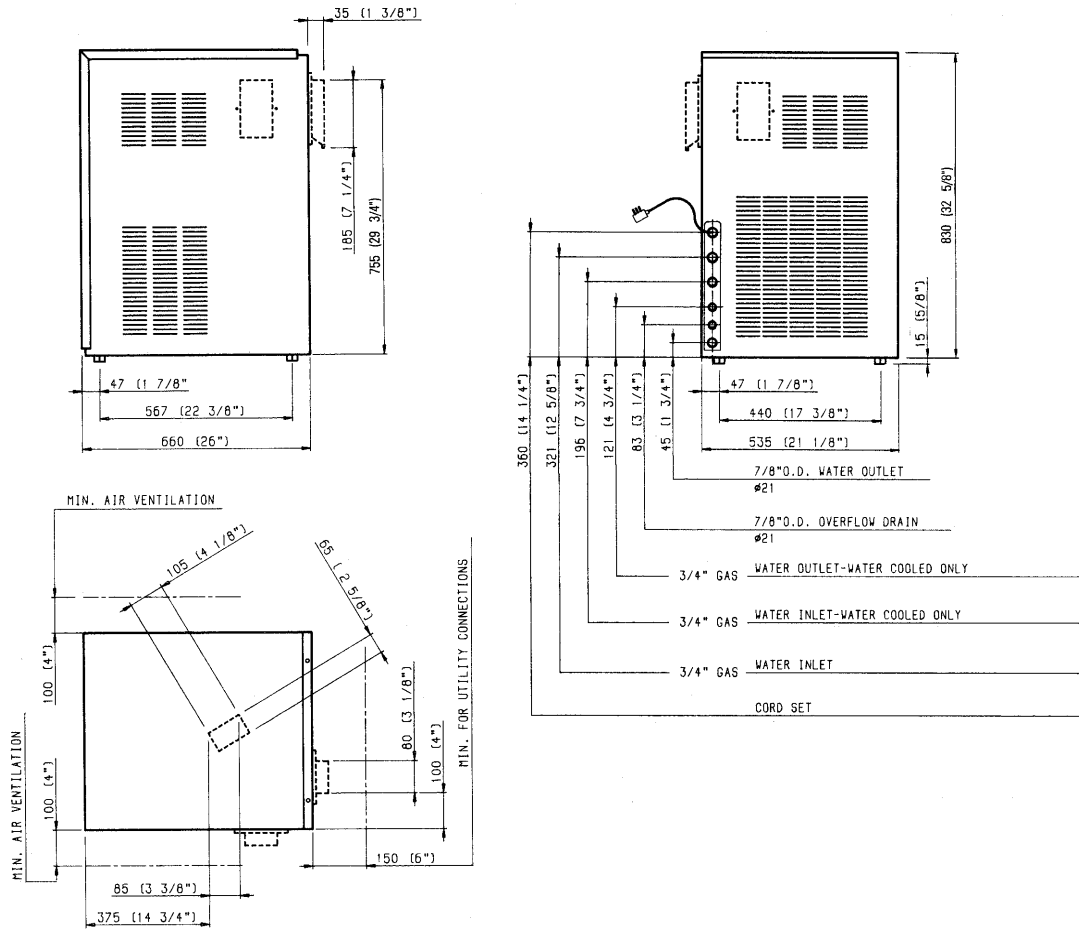

Dimensions:
 HEIGHT (less legs) 830 mm.
 HEIGHT (with legs) 845 mm.
 WIDTH 535 mm.
 DEPTH 660 mm.
 WEIGHT 93 Kg.

SF 500 - MACHINE SPECIFICATIONS

Model		Cond. unit		Finish		Comp. HP		Water req. l/24 HR	
SF 500 INOX SF 500 W INOX		Air Water		S. Steel		1.5		550 3000*	
Basic electr.	Amps	Start Amps	Watts	Electric power cons. Kwh per 24 HR		Nr. of wires		Amps fuse	
220-230/50/1 380-400/50/3+N	9.5 4.2	50 23	1800	43 40		3 x 1.5 mm ²		16	
* A 15°C water temperature									

SPECIFICATIONS

**ELECTRONIC MODULAR SUPERFLAKER
MODEL SF 1000 (R 404a)**

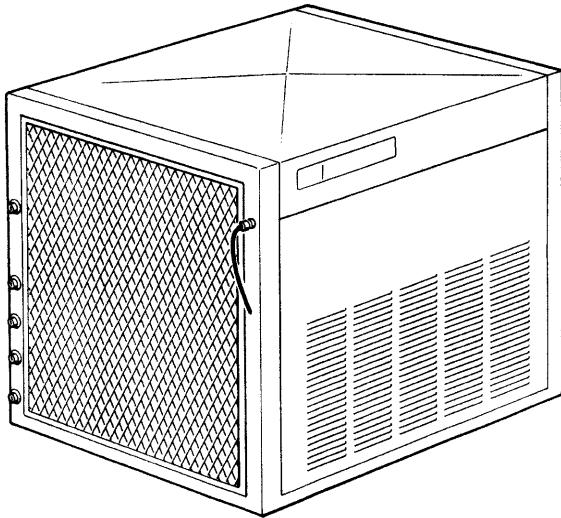

Important operating requirements:

	MIN	MAX
• Air temperature	10°C (50°F)	40°C (100°F)
• Water temperature	5°C (40°F)	40°C (100°F)
• Water pressure	1 bar (14 psi)	5 bars (70 psi)
• Electr. voltage variations from voltage rating specified on nameplate	-10%	+6%

ice making capacity

KG/24 H

1036	1090	1120	1150
980	1030	1060	1080
975	1025	1055	1075
950	1000	1030	1070
32	21	15	10

SF 1000 W
RAFFR. ACQUA
WATER COOLED

10
21
32
38

950	1050	1100	1150
870	970	1020	1070
770	870	920	970
720	820	870	920
32	21	15	10

SF 1000 A
RAFFR. ARIA
AIR COOLED

°C TEMPERATURA AMBIENTE
AMBIENT TEMPERATURE

°C TEMPERATURA ACQUA
WATER TEMPERATURE

NOTE. The daily ice-making capacity is directly related to the condenser air inlet temperature, water temperature and age of the machine.
To keep your **FLAKER** at peak performance levels, periodic maintenance checks must be carried out as indicated on page 43 of this manual.

SPECIFICATIONS

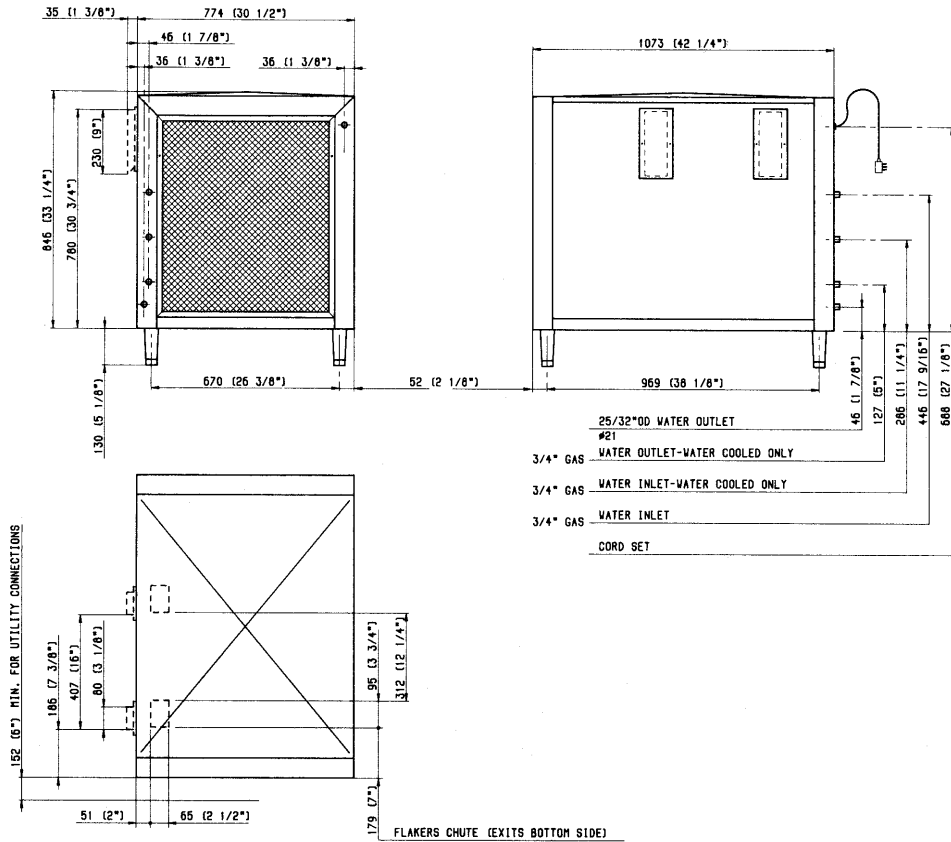

Dimensions:

HEIGHT (less legs)	846 mm.
HEIGHT (with legs)	976 mm.
WIDTH	1073 mm.
DEPTH	774 mm.
WEIGHT	242 Kg.

SF 1000 - MACHINE SPECIFICATIONS

Model	Cond. unit	Finish	Comp. HP	Water req. l/24 HR		
SF 1000 INOX SF 1000 W INOX	Air Water	S. Steel	5	1100 8000*		
Basic electr.	Amps	Start Amps	Watts	Electric power cons. Kwh per 24 HR	Nr. of wires	Amps fuse
220/50/3 380/50/3 + N	12 6.5		2500	60	5 x 2.5 mm ²	
* A 15°C water temperature						

GENERAL INFORMATION AND INSTALLATION

A. INTRODUCTION

This manual provides the specifications and the step-by-step procedures for the installation, start-up and operation, maintenance and cleaning for the **F 100, F 100C, F 200, SF 300, SF 500** and **SF 1000** Modular Icemakers.

The Electronic Flakers and Superflakers are quality designed, engineered and manufactured. Their ice making systems are thoroughly tested providing the utmost in flexibility to fit the needs of a particular user.

This product qualifies for the following listings:



These icemakers have been engineered to our own rigid safety and performance standards. The VDE - SEV - WRC seals signify that it is listed with them and that it complies with the materials and manufacturing standard of them. These seals also signify that these icemaker models have been inspected and tested by VDE - SEV - WRC inspectors who reserve the right to periodically examine production icemakers at the factory to assure continued compliance.

NOTE. *To retain the safety and performance built into this icemaker, it is important that installation and maintenance be conducted in the manner outlined in this manual.*

Storage Bin

Since the series Modular Flakers do not have their own attached ice storage bins, it is necessary to use an auxiliary bin as detailed herebelow:

D 100 in combination with **F 100** and **F 200**.

D 200 with its companion **NKF 200** Top Cover in combination with **F 100, F 200, SF 300** and **SF 500**.

D 310 with its companion **NKF 310** Top Cover in combination with **F 100, F 200, SF 300** and **SF 500**.

B 30 in combination with **SF 300** and **SF 500**.

B 50 in combination with **SF 300** and **SF 500**.

B. UNPACKING AND INSPECTION

Icemaker

1. Call your authorized Distributor or Dealer for proper installation.

2. Visually inspect the exterior of the packing and skid. Any severe damage noted should be reported to the delivering carrier and a concealed damage claim form filled in subject to inspection of the contents with the carrier's representative present.

3. a) Cut and remove the plastic strip securing the carton box to the skid.

b) Remove the packing nails securing the carton box to the skid.

c) Cut open the top of the carton and remove the polystyrene protection sheet.

d) Pull out the polystyrene posts from the corners and then remove the carton.

4. Remove the front and the sides panels of the unit and inspect for any concealed damage. Notify carrier of your claim for the concealed damage as stated in step 2 above.

5. Remove all internal support packing and masking tape.

6. Check that refrigerant lines do not rub against or touch other lines or surfaces, and that the fan blades move freely.

7. Check that the compressor fits snugly onto all its mounting pads.

8. See data plate on the rear side of the unit and check that local main voltage corresponds with the voltage specified on it.

CAUTION. **Incorrect voltage supplied to the icemaker will void your parts replacement program.**

9. Remove the manufacturer's registration card from the inside of the User Manual and fill-in all parts including: Model and Serial Number taken from the data plate.

Forward the completed self-addressed registration card to CASTELMAC factory.

Storage bin (D 100 - D 200 - D 310)

1. Follow the steps 1, 2 and 3 above to unpack the storage bin.

2. Unloose the two bolts and remove the protection plate from the drain fitting.

3. Carefully lay it down on its rear side and fit the four legs into their sockets.

4. Remove all internal support packing and masking tape as well as the plastic ice cube deflector which is not need being used with the Modular Cubers only.

5. Remove the manufacturer's registration card from the inside of the User Manual and fill in all parts including: Model and Serial Number taken from the data plate. Forward the completed self-addressed registration card to CASTELMAC factory.

Storage bin (B 30 - B 50)

1. Follow the steps 1, 2 and 3 above to unpack the storage bin.
2. Lay carefully down the bin on its back to protect the finish and remove the bolts holding the shipping skid to the bin.
3. Screw-in the legs into the corresponding tapped holes in the bin bottom and tighten to seat the legs well against the bin bottom.
4. Connect the water drain line to the 1" female drain fitting located in the bottom of the bin.

NKF 200 - NKF 310 Top Cover

1. Follow the steps 1 and 2 above to unpack the storage bin.
3.
 - a) Cut and remove the plastic strip securing the carton box to the skid.
 - b) Cut open the top of the carton and remove the polystyrene protection sheet.
 - c) Pull out the NKF 200 - NKF 310 Top Cover together with the mushroom shape plastic connection chute.

C. LOCATION AND LEVELLING

WARNING. This Modular Flaker and Superflaker is designed for indoor installation only. Extended periods of operation at temperature exceeding the following limitations will constitute misuse under the terms of the CASTELMAC Manufacturer's Limited Warranty resulting in **LOSS** of warranty coverage.

1. Position the storage bin in the selected permanent location.

Criteria for selection of location include:

a) Minimum room temperature 10°C (50°F) and maximum room temperature 40°C (100°F).

b) Water inlet temperatures: minimum 5°C (40°F) and maximum 40°C (100°F).

c) Well ventilated location for air cooled models (clean the air cooled condenser at frequent intervals).

d) Service access: adequate space must be left for all service connections through the rear of the ice maker. A minimum clearance of 15 cm (6") must be left at the sides of the unit for routing cooling air drawn into and exhausted out of the compartment to maintain proper condensing operation of air cooled models.

2. Level the Storage Bin Assy in both the left to right and front to rear directions by means of the adjustable legs.

3. On **D 200** and **D 310 Storage Bin** inspect its top mounting gasket which should be flat with no wrinkles, to provide a good sealing when the NKF 200 - NKF 310 Top Cover is installed on top of it.

4. Place the NKF 200 and NKF 310 Top Cover on top of Storage bin using care not to wrinkle or tear the gasket

5. **On the B 1025 S and B 1350 S Storage Bin** unloose the screws securing the S.S. Top Cover to the storage bin and remove it.

6. Lay out on the bin top the plan of the ice machine as it will be located on the bin and cut an opening in the bin top for the ice drop area; cover the edges of the opening with vinyl tape

7. Install the gasket on the bin top-around ice drop opening of the bin top; apply sealant along the inside of the gasket.

8. Position and install the four aluminium front to rear stiffeners (U shaped) paying attention to the guideline shown on the drawing.

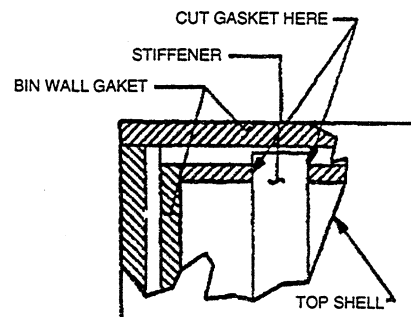

NOTE. Bin wall gasket must be cut to clear the stiffener ends as shown on drawing. Do not put any stiffeners crossing the ice drop opening

9. Install the bin top in its position onto the bin top by:

- place the rear side of top against rear edge of the bin
- lower the front of the top onto the stiffeners
- re-fit the screws previously removed as per step 5

10. Install the Modular Flaker or Superflaker onto the Top Cover of storage bin pay attention to match the ice chute with the Bin Top opening.

D. ELECTRICAL CONNECTIONS

See data plate for current requirements to determine wire size to be used for electrical connections. All icemakers require a solid earth wire.

All SCOTSMAN ice machines are supplied from the factory completely pre-wired and require only electrical power connections to the wire cord provided at the rear of the unit.

Make sure that the ice machine is connected to its own circuit and individually fused (see data plate for fuse size).

The maximum allowable voltage variation should not exceed -10% and + 6% of the data plate rating. Low voltage can cause faulty functioning and may be responsible for serious damage to the overload switch and motor windings.

NOTE. All external wiring should conform to national, state and local standards and regulations.

Check voltage on the line and the ice maker's data plate before connecting the unit.

E. WATER SUPPLY AND DRAIN CONNECTIONS

GENERAL

When choosing the water supply for the ice flaker consideration should be given to:

- a) Length of run
- b) Water clarity and purity
- c) Adequate water supply pressure

Since water is the most important single ingredient in producing ice you cannot emphasize too much the three items listed above.

Low water pressure, below 1 bar may cause malfunction of the ice maker unit.

Water containing excessive minerals will tend to produce scale build-up on the interior parts of the water system while too soft water (with too low contents of mineral salts), will produce a very hard flaker ice.

WATER SUPPLY

Connect the 3/4" GAS male of the water inlet fitting, using a food grade flexible tubing or a 3/8" O.D. copper pipe, to the cold water supply line with regular plumbing fitting and a shut-off valve installed in an accessible position between the water supply line and the unit.

If water contains a high level of impurities, it is advisable to consider the installation of an appropriate water filter or conditioner.

WATER SUPPLY - WATER COOLED MODELS

The water cooled versions of Ice Makers require two separate inlet water supplies, one for the water cooled condenser.

Connect the 3/4" GAS male fitting of the water inlet, using flexible tubing or a 3/8" O.D. copper pipe, to the cold water supply line with regular plumbing fitting and a shut-off valve installed in an accessible position between the water supply line and the unit.

WATER DRAIN

The recommended drain tube is a plastic or flexible tube with 18 mm (3/4") I.D. which runs to an open trapped and vented drain. When the drain is a long run, allow 3 cm pitch per meter (1/4" pitch per foot).

Install a vertical open vent on drain line high point at the unit drain connection to ensure good draining.

The ideal drain receptacle is a trapped and vented floor drain.

WATER DRAIN - WATER COOLED MODELS

Connect the 3/4" GAS male fitting of the condenser water drain, utilizing a second flexible tubing or a 3/8" O.D. copper tubing, to the open trapped and vented drain.

This additional drain line must not interconnect to any other of the units drains.

NOTE. The water supply and the water drain must be installed to conform with the local code. In some case a licensed plumber and/or a plumbing permit is required.

F. FINAL CHECK LIST

1. Is the unit in a room where ambient temperatures are within a minimum of 10°C (50°F) even in winter months?
2. Is there at least a 15 cm (6") clearance around the unit for proper air circulation?
3. Is the unit level? (IMPORTANT)
4. Have all the electrical and plumbing connections been made, and is the water supply shut-off valve open?
5. Has the voltage been tested and checked against the data plate rating?
6. Has the water supply pressure been checked to ensure a water pressure of at least 1 bar (14 psi).

7. Have the bolts holding the compressor down been checked to ensure that the compressor is snugly fitted onto the mounting pads?
8. Check all refrigerant lines and conduit lines to guard against vibrations and possible failure.
9. Have the bin liner and cabinet been wiped clean?
10. Has the owner/user been given the User Manual and been instructed on the importance of periodic maintenance checks?
11. Has the Manufacturer's registration card been filled in properly? Check for correct model and serial number against the serial plate and mail the registration card to the factory.
12. Has the owner been given the name and the phone number of the authorized Service Agency serving him?

G. INSTALLATION PRACTICE

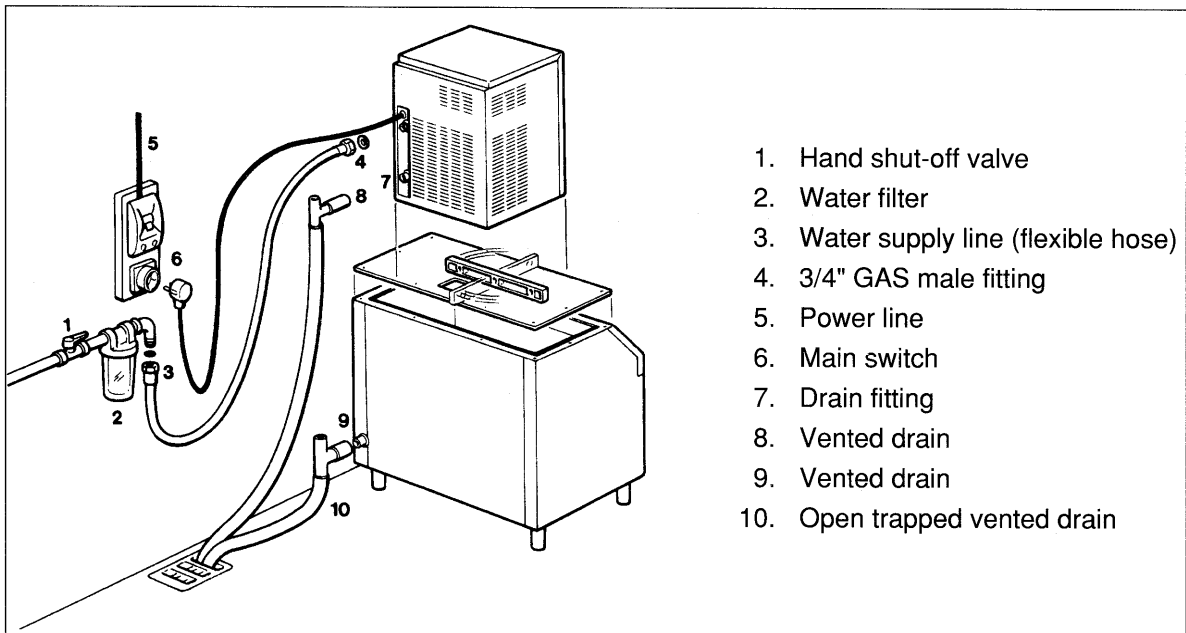

WARNING. This icemaker is not designed for outdoor installation and will not function in ambient temperatures below 10°C (50°F) or above 40°C (100°F). This icemaker will malfunction with water temperatures below 5°C (40°F) or above 40°C (100°F).

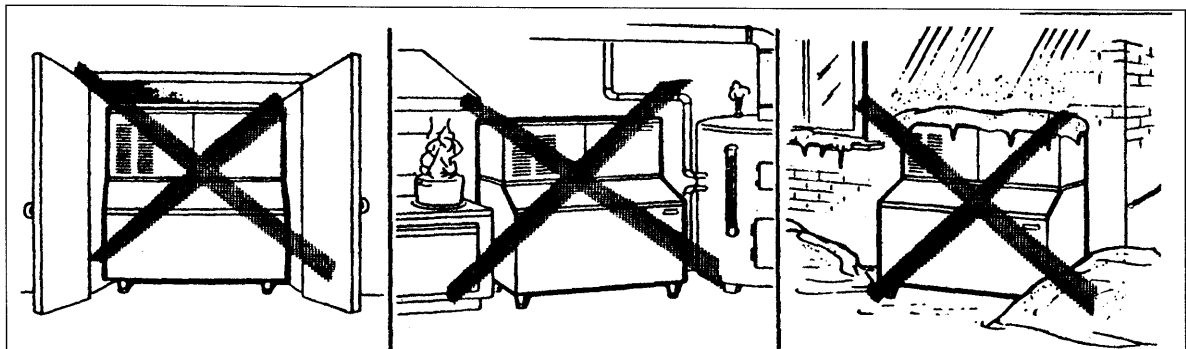

OPERATING INSTRUCTIONS

START UP

After having correctly installed the ice maker and completed the plumbing and electrical connections, perform the following "Start-up" procedure.

- A.** Open the water supply line shutoff valve and put the unit under electrical power by moving the main switch, on the power supply line, to the ON position. The **first LED - GREEN** - will glow to signal that unit is under power.

NOTE. Everytime the unit is put under power, after being kept for sometime in shut-off conditions (electrically disconnected) the **RED LED** will blink for 3 minutes after which the unit will start up with the immediate operation of the gear motor assembly and, after 5 seconds, of the compressor assy (Fig.1).

- B.** Elapsed the 3 minutes - stand by period - the unit starts operating with the activation in sequence of the following assemblies:

GEAR MOTOR/S

COMPRESSOR

FAN MOTOR/S (if unit is an air cooled version) kept under control by the condenser temperature sensor which has its probe within the condenser fins (Fig.2).

- C.** Elapsed 2 or 3 minutes from the compressor start up, observe that flaker ice begins dropping off the ice spout to fall through the ice chute into the storage bin.

NOTE. The first ice bits that drop into the ice storage bin are not so hard as the evaporating temperature has not yet reached the correct operating value. It is necessary to allow the ice - just made - to cure itself and wait for about ten minutes for the evaporating temperature to reach the correct value so to make more hard bits of ice.

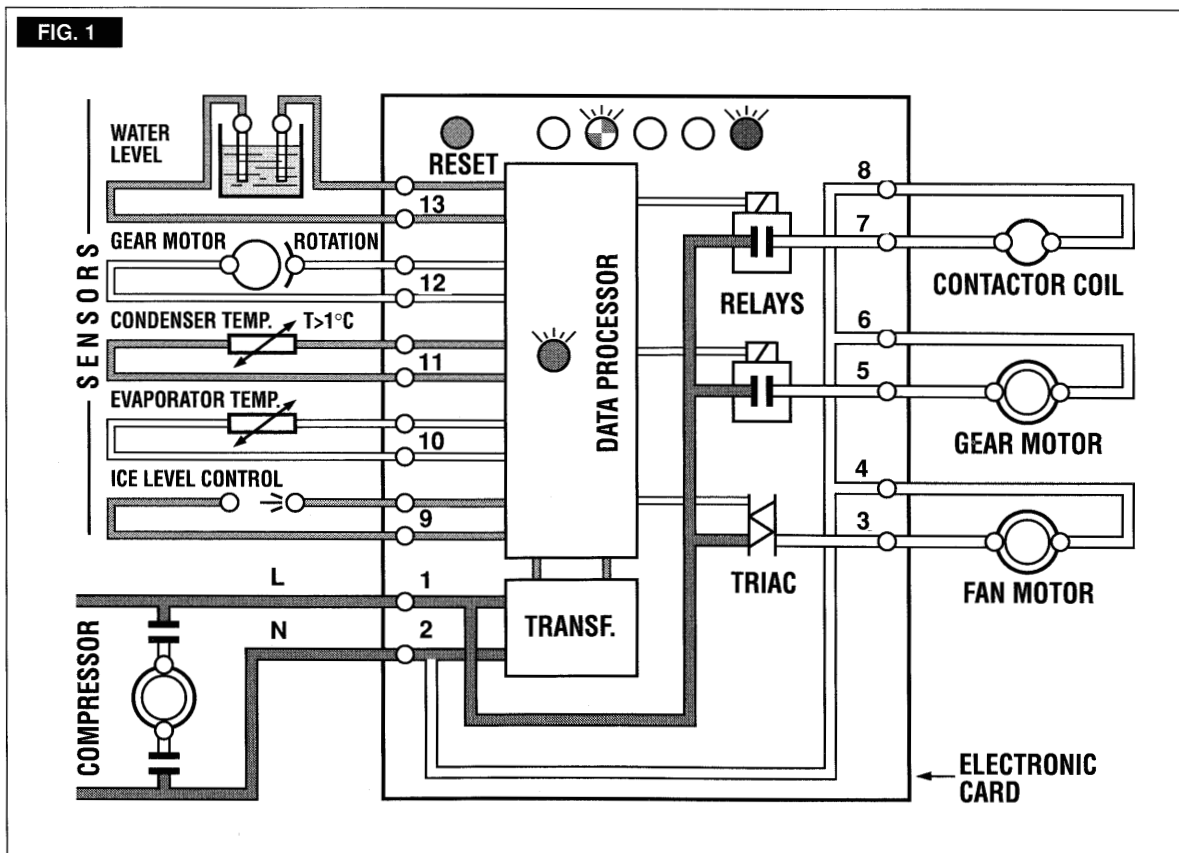

FIG. 2

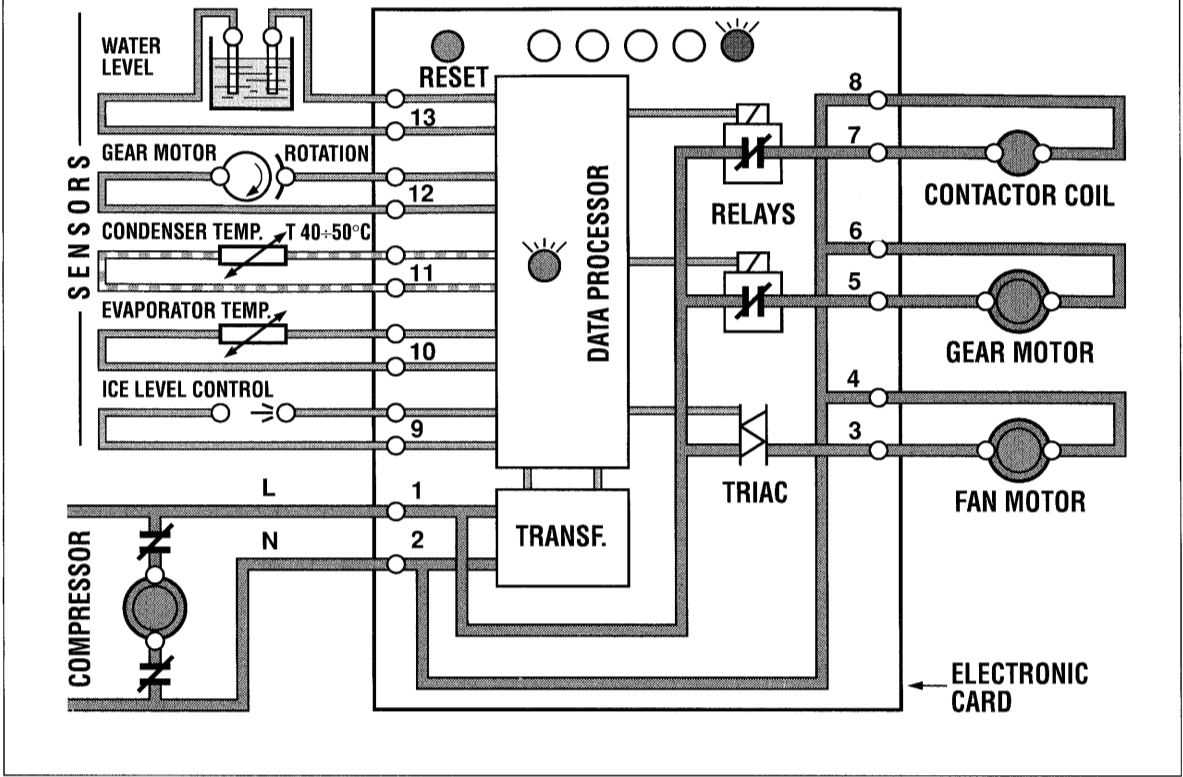
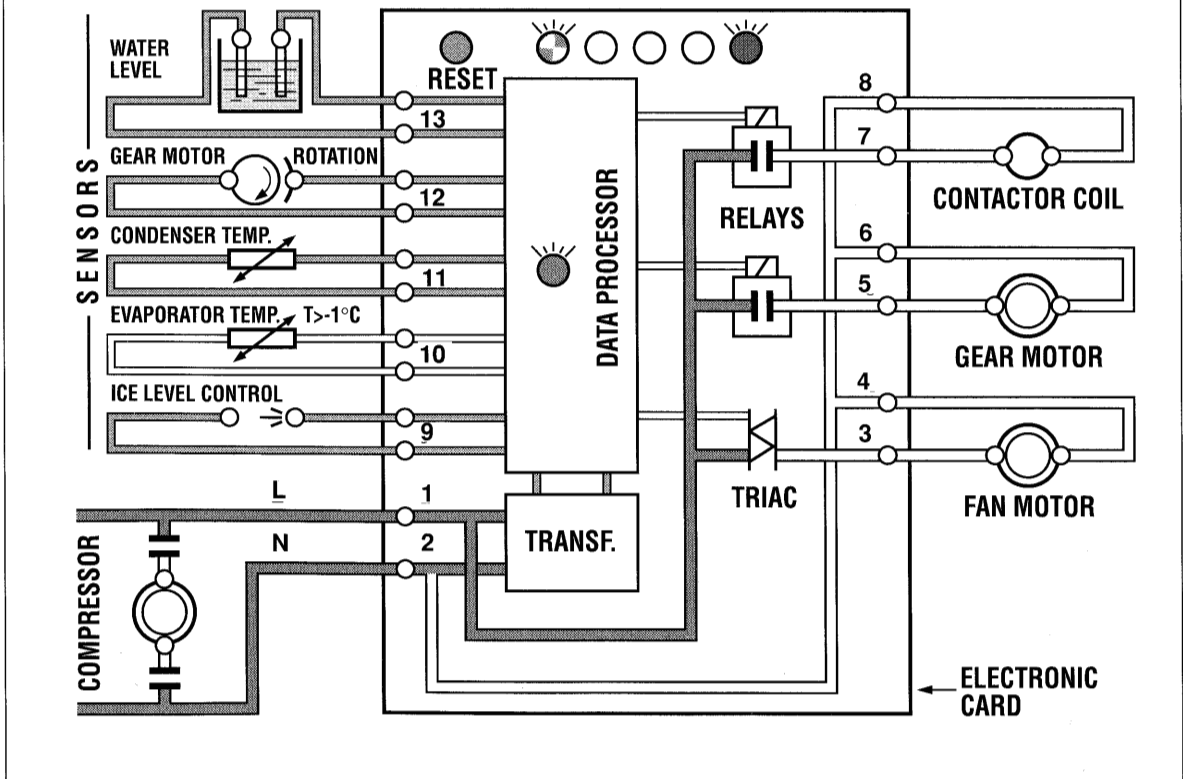

FIG. 3



NOTE. If, after ten minutes from the compressor start-up, the evaporating temperature has not dropped down to a value lower than -1°C (30°F) due to an insufficient quantity of refrigerant in the system, the evaporating temperature sensor detects such an abnormal situation and stops consequently the unit operation. In this circumstance, the **5th warning YELLOW LED** will blink (Fig.3).



After having diagnosed and eliminated the cause of the poor evaporating temperature (insufficient refrigerant in the system or excessive condensing temperature) it is necessary to push the **RE-SET BUTTON** that protrudes through the hole of the control box cover. The unit, before resuming the total operation, will go through the **usual 3 minutes STAND-BY period**.

NOTE. On air cooled models, the condenser temperature sensor, which is located within the condenser fins, keeps the head (condensing) pressure between 13.5 and 14.5 bars (190-205 psig). In the event of condenser clogged - such to prevent the proper flow of the cooling air - or, in case the fan motor is out of operation, the condenser temperature rises and when it reaches 75°C (170°F) the condenser temperature sensor shuts-off the ice maker with the consequent light-up of the **RED WARNING LIGHT** (Fig.4).



After having diagnosed the reason of the temperature rise and removed its cause, it is necessary to proceed as per the previous "NOTE" to start up again the operation of the ice maker.

OPERATION CHECKS UPON THE UNIT START UP

D. Remove front service panel and, if necessary, install the refrigerant service gauges on the corresponding Schröder valves to check both the HI and LO refrigerant pressures.

E. Check for the correct CUT-OUT and CUT-IN of the **float reservoir water level sensors** by first shutting closed the water shutoff valve on the water supply line.

FIG. 4

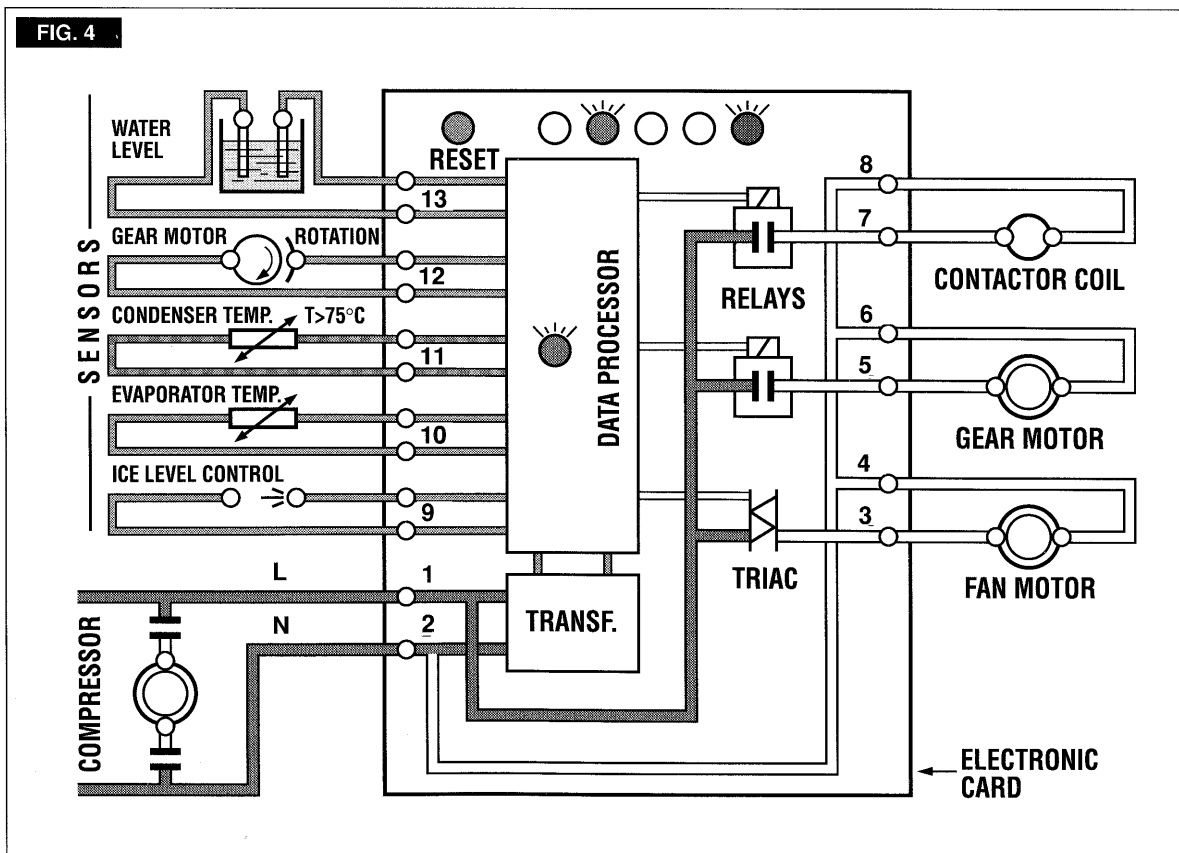

This will cause a gradual decrease of the water level in the float reservoir and as soon as the level gets below the sensors, the flaker stops to operate and the **YELLOW warning LED** will glow to signal the shortage of water (Fig.5).



NOTE. The water level sensor detects the presence of sufficient water in the float reservoir and confirms it to the micro processor by maintaining a low voltage current flow between the two sensors using the water as conductor.

WARNING. The use of de-mineralized water (water with no salt content) having an electrical conductivity lower than 30 μ S, will cause the ability of the water sensors to vanish with the consequent **CUT-OUT** of the flaker operations and the glowing of the **YELLOW LED** of shortage of water, even though that the water is indeed in the reservoir.

After this open the water supply line shutoff valve to fill up again the float reservoir, the **YELLOW LED** goes off while the **RED LED starts blinking**. After 3 minutes the unit resumes its total operation with the immediate start-up of the gear motor and, 5 seconds later, of the compressor:

F. Check for the correct operation of the electronic eye (one per each ice chute on model SF 1000) for the ice bin level control, by placing one hand between the sensing "eyes" located in the ice spout, to interrupt the light beam. This interruption will cause an immediate extinguishing of the **RED LED** located on the front of the P.C. Board and after about 10 seconds causes the shutoff of the unit with the simultaneous lighting of the **YELLOW LED** signalling the **full bin situation** (Fig. 6).



Allow the resumption of the light beam previously interrupted and after about 10 seconds the flaker will resume - through the 3 minutes **STAND-BY** period - the ice making process with the extinguishing of the **YELLOW LED**.

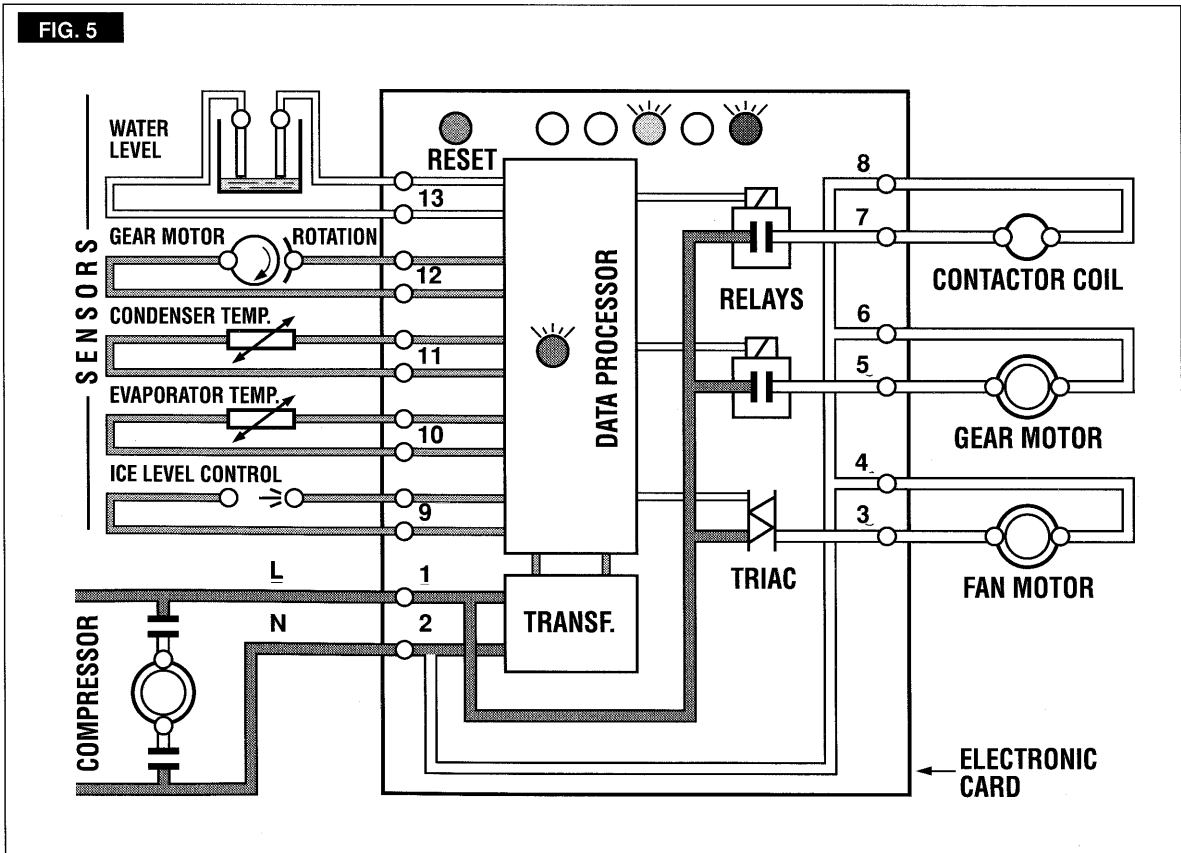

NOTE. The **ICE LEVEL CONTROL (INFRARED SYSTEM)** is independent of the temperature however, the reliability of its detection can be affected by external light radiations or by any sort of dirt and scale sediment which may deposit directly on the light source and on the receiver.

To prevent any possible ice maker malfunction, due to negative affection of the light detector, it is advisable to locate the unit where it is not reached by any direct light beam or light radiation, also it is recommended to keep the bin door constantly closed and to follow the instructions for the periodical cleaning of the light sensor elements as detailed in the **MAINTENANCE AND CLEANING PROCEDURES**.

M. If previously installed, remove the refrigerant service gauges and re-fit the unit service panels previously removed.

N. Instruct the owner/user on the general operation of the ice machine and about the cleaning and care it requires.

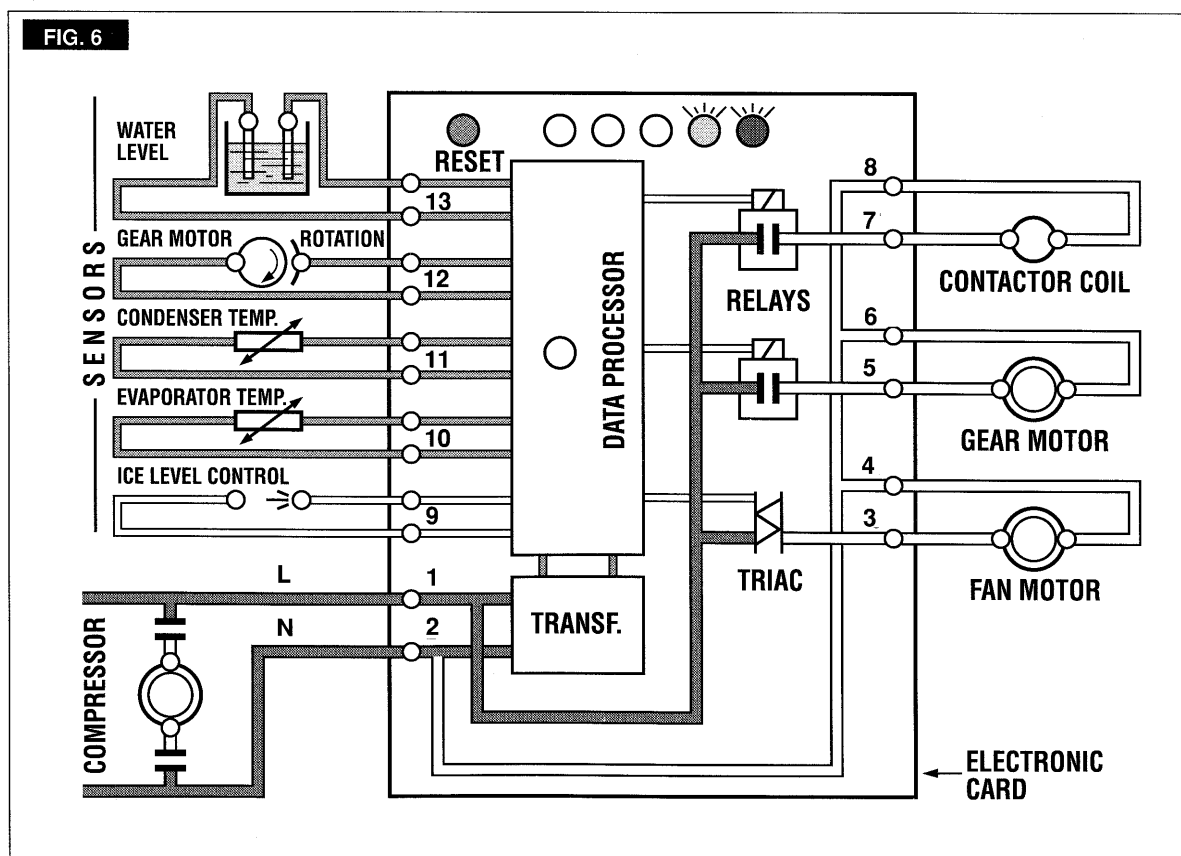

PRINCIPLE OF OPERATION

WATER CIRCUIT

The water enter in the machine through the water inlet fitting which incorporates a strainer and it is located at the rear side of the cabinet and then it goes to the water reservoir flowing through a float valve.

NOTE. The presence of the water in the float reservoir is detected by a system of two sensors which operates in conjunction with the P.C. Board. The two sensors use the water as a conductor to maintain a low voltage current flow between them signalling in this way to the P.C. Board the presence of the water in the reservoir. In case the water used is very soft (de-mineralized) or the float reservoir gets empty the current flow between the sensors become so weak or is no longer maintained that, as consequence, the P.C. Board shutoff the flaker operation with the simultaneous glowing of the **YELLOWLED** signalling "Shortage of water".

The float reservoir is positioned at the side of the freezing cylinder at such an height to be able to maintain a constant water level around the freezer auger. In fact, the water flows from the reservoir into the bottom inlet of the freezing cylinder to surround the stainless steel auger which is vertically fitted in the center of the freezer.

In the freezer the incoming water gets chilled into soft (slush) ice which is moved upward by the rotating action of the auger. The stainless steel auger that rotates counter-clockwise within the freezer, is powered by a direct drive gear motor and carries the ice upward along the refrigerated freezer inner walls and by doing so the ice gets progressively thicker and harder.

The ice, being constantly lifted up, meet the teeth of the ice breaker which is fitted on the top end of the auger, where it gets compacted, cracked and forced to change from vertical into horizontal

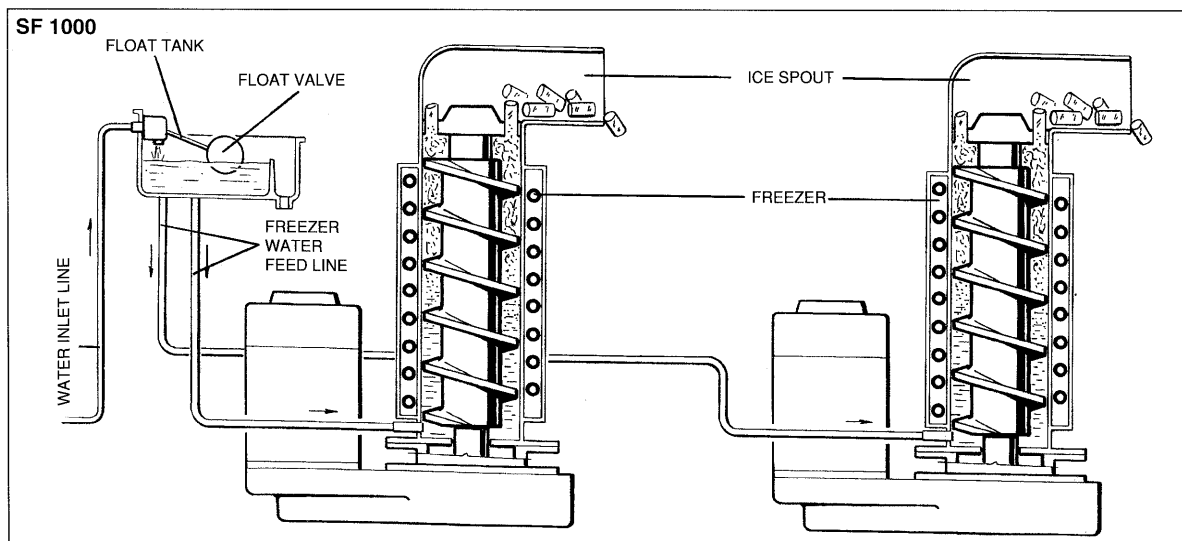
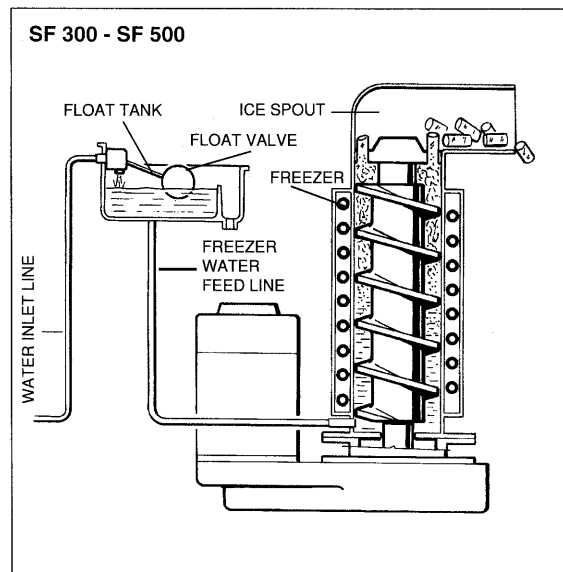
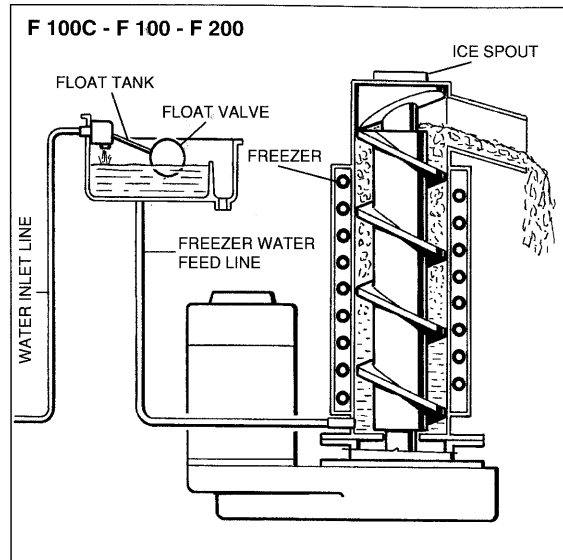

motion to be discharged out, through the ice spout and chute, into the storage bin.

By running the ice maker, i.e. by putting the unit under power, starts the automatic and continuous icemaking process which would not stop until the ice storage bin gets filled-up to the level of the control "eyes" located on the sides of the ice chute. As the ice level raises to interrupt the light beam running between the two infrared lamps (one or both on model SF 1000), the unit stops after ten seconds, with the simultaneous glowing of the **YELLOW LED** signalling the "Full Bin" situation.

NOTE. The interruption of the light beam between the two light sensors is immediately signalled by the extinguishing of the **RED LED** located on the front of the P.C. Board. After about **10"** of steady interruption of the light beam the unit stops and the "Full Bin" **YELLOW LED** glows.

The ten seconds of delay prevent the unit from stopping for any undue reason like the momentarily interruption of the light beam caused by the flakes that slides along the ice spout before dropping into the bin.

As some ice gets scooped out from the storage bin, the light beam between the two sensors resumes and immediately the **RED LED** in the front-center of the P.C. Board lights-up; ten seconds later the ice machine restarts the ice making process and the **YELLOW LED** goes off.

REFRIGERANT CIRCUIT

The hot gas refrigerant discharged out from the compressor reaches the condenser where, being cooled down, condenses into liquid.

Flowing into the liquid line it passes through the drier filter, then it goes all the way through the capillary tube where it loses some of its pressure so that its pressure and temperature are lowered. Next, the refrigerant enters into the evaporator coil wrapped around the freezer inner tube.

The water being constantly fed at the interior of the freezer inner tube, exchange heat with the refrigerant circulating into the evaporator coil, this cause the refrigerant to boil-off and evaporate, thereby it changes from liquid into vapor.

The vapor refrigerant then passes through the suction accumulator and through the suction line where the refrigerant exchanges heat with the one flowing into the capillary tube (warmer) before being sucked into the compressor to be recirculated.

The refrigerant head pressure is kept between two pre-set values (8÷9 [F100] 17÷18 bars [200-300-500-1000]) by the condenser temperature sensor which has its probe located within the condenser fins - in air cooled versions.

This condenser temperature sensor, when senses a rising of the condenser temperature beyond the pre-fixed limit, changes its electrical resistance and send a low voltage power flow to the **MICRO-PROCESSOR** of the P.C. Board which energizes, through a **TRIAC**, the **Fan Motor** in **ON-OFF** mode.

When the opposite situation occurs, i.e. the condenser temperature gets below the pre-fixed limit, the temperature sensor changes again its electrical resistance reducing therefore the current flow to the P.C. Board to cause a temporary stop of the Fan Motor.

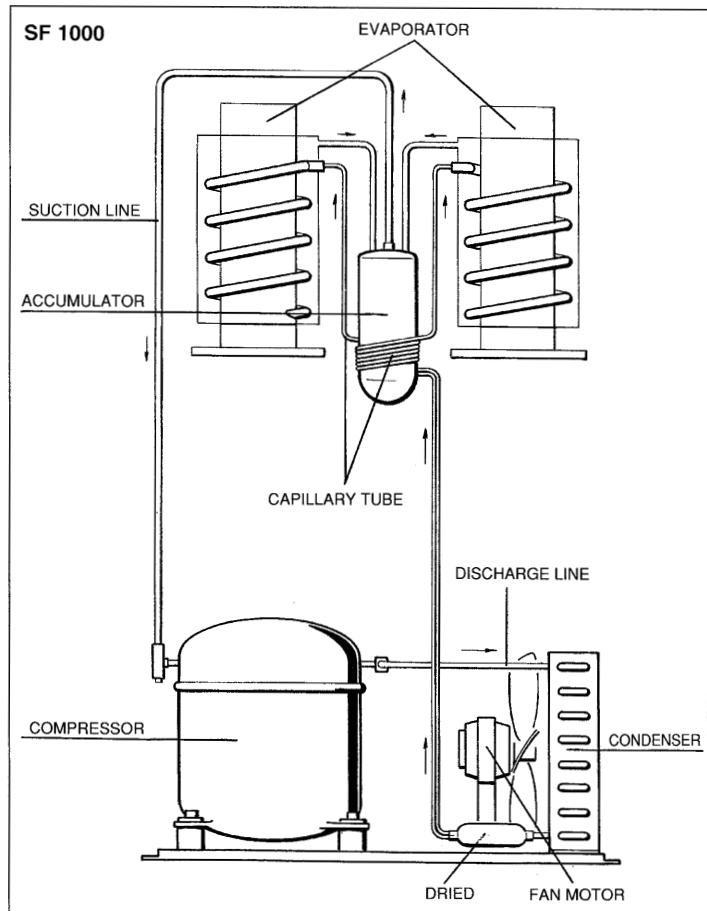
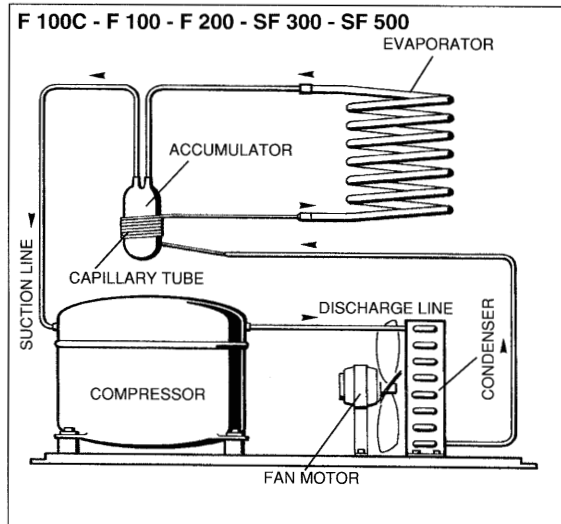

On the water cooled versions, the refrigerant head pressure is kept at the constant value of **8,5 bars [F100] 17 bars [200-300-500-100]** by the metered amount of water passing through the condenser which is regulated by the action of the Water Regulating Valve that has its capillary tube connected to the liquid refrigerant line. As pressure increases, the water regulating valve opens to increase the flow of cooling water to the condenser.

NOTE. In case the condenser temperature probe senses that the condenser temperature has risen to 75°C (170°F) for one of the following abnormal reasons:

CLOGGED CONDENSER (Air cooled version)

INSUFFICIENT FLOW OF COOLING WATER (Water cooled version)

FAN MOTOR OUT OF OPERATION (Air cooled version)

AMBIENT TEMPERATURE HIGHER THEN 43°C (110°F)

it causes the total and immediate **SHUT-OFF** of the machine in order to prevent the unit from operating in abnormal and dangerous conditions.

When the ice maker stops on account of this protective device, there is a simultaneous glowing of the **RED LED**, warning the user of the **Hi Temperature** situation.

After having eliminated the source of the excessive condenser temperature, to restart the ice machine it is necessary to push the **RE-SET** button that protrudes through the control box cover.

The **RED LED** starts blinking and three minutes later the flaker unit resume its normal operating mode. The condenser temperature sensor has a further safety function which consist in preventing the unit from operating in Lo-ambient conditions i.e. when the condenser body temperature - equivalent to the ambient temperature - is **lower then 1°C 34°F** (Fig.7).

Even in this situation, to be able to run the machine, after having remedied to the Lo-ambient condition, it is necessary to press the **RE-SET Push Button**.

The refrigerant suction or Lo-pressure sets - in normal ambient conditions - on the value of **0,5 bars [F100] 2,4÷2,6 bars [200-300-500-100]** after few minutes from the unit start-up.

This value can vary of **0.1 or 0.2 bars (1.5÷3 psig)** in relation to the water temperature variations influencing the freezer cylinder.

NOTE. If, after ten minutes from the unit start up, no ice is made and the evaporating temperature detected by the evaporator sensor results to be higher than -1°C (30°F) the ice maker stops and the **5th WARNING YELLOW LED** blinks.

FIG. 7

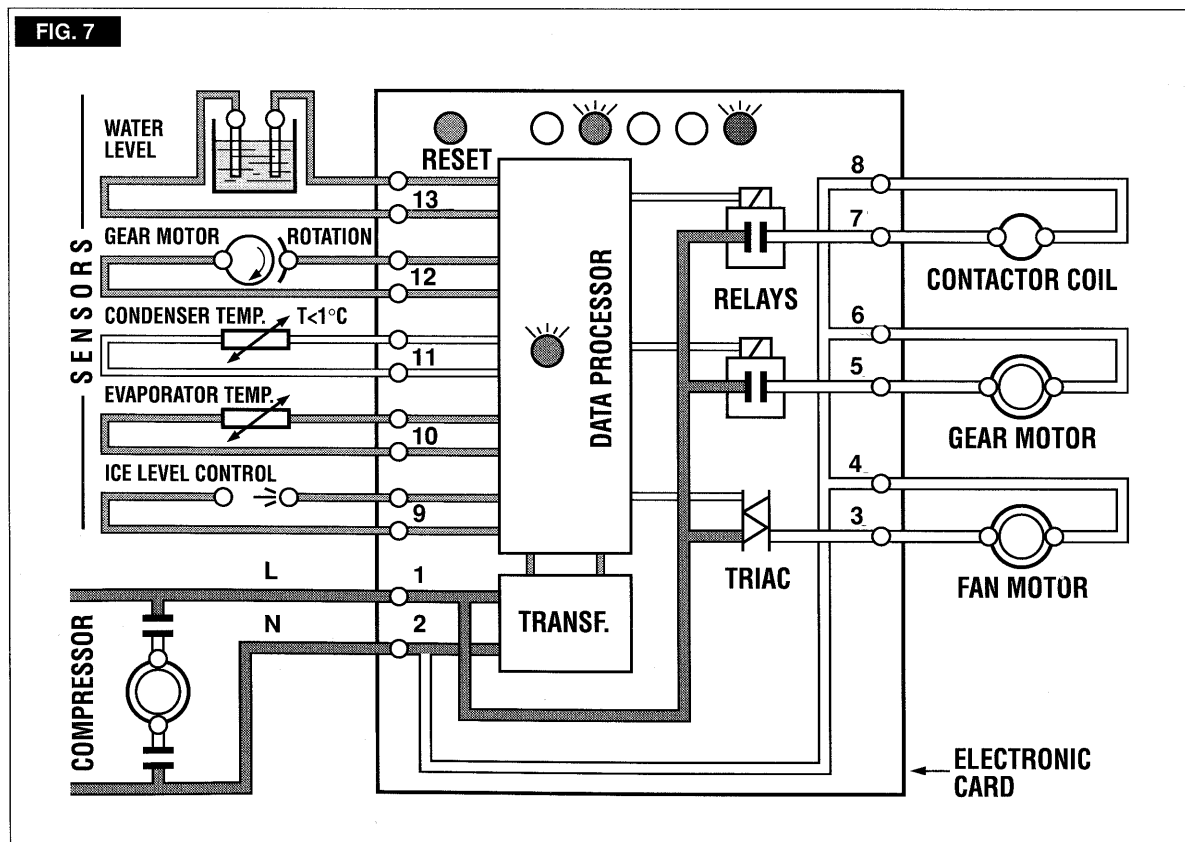

MECHANICAL SYSTEM

The mechanical system of the Flaker machines consists basically of a gear motor assembly (two on model SF 1000) which drives, through a ratched coupling, a worn shaft or auger placed on its vertical axis within the freezing cylinder (two on model SF 1000).

The gear motor is made of a single phase electric motor with a permanent capacitor. This motor is directly fitted in the gear case through which it drives - in counter clockwise rotation at a speed of 9.5 r.p.m. - the freezer auger being linked to it by the ratched coupling.

NOTE. In the event the gear motor (one of the two on MF 61) will tend to rotate in the wrong direction (counterclockwise) the unit will **stop immediately** with the glowing of the **WARNING YELLOW LED** on account of the intervention of the **Electromagnetic Safety Device** - based on Hall Effect principle. After having diagnosed and eliminated the source of the gear motor wrong rotation, to restart the unit it is necessary to press the **RE-SET** push button or switch **OFF** and **ON** the power line main disconnect switch (Fig. 8).



The **RED LED** will start blinking and after 3 minutes the ice maker will resume its total operations by running first the gear motor and then the compressor.

Too low ambient and water temperature (well below the limitations of respectively 10°C and 5°C - 50°F and 40°F) or frequent interruptions of the water supply to the freezing cylinder (clogging of the water hose connecting the float reservoir to the water inlet at the bottom of the freezer) may cause the ice to get too hard and compact losing fluidity and thereby seizing the auger.

This situation will put under excessive strain and load the entire drive system and freezer bearings.

When the gear motor rotating speed is slowed **below 1300 r.p.m.** from the normal speed of 1400 r.p.m. the Electromagnetic Safety Device transmits an electrical signal to the **MICROPROCESSOR** to **stop immediately** the unit operations like it occurs for the wrong rotation, with the lighting-up of the **YELLOW WARNING LED**.

This to relieve from the excessive load all the electrical and mechanical components of the entire Drive System and extend their durability.

NOTE. After having diagnosed and eliminated the source of the gear motor slow rotation to restart the unit it is necessary to press, also in this case, the **RE-SET** push button or switch **OFF** and **ON** the power line main switch.

FIG. 8

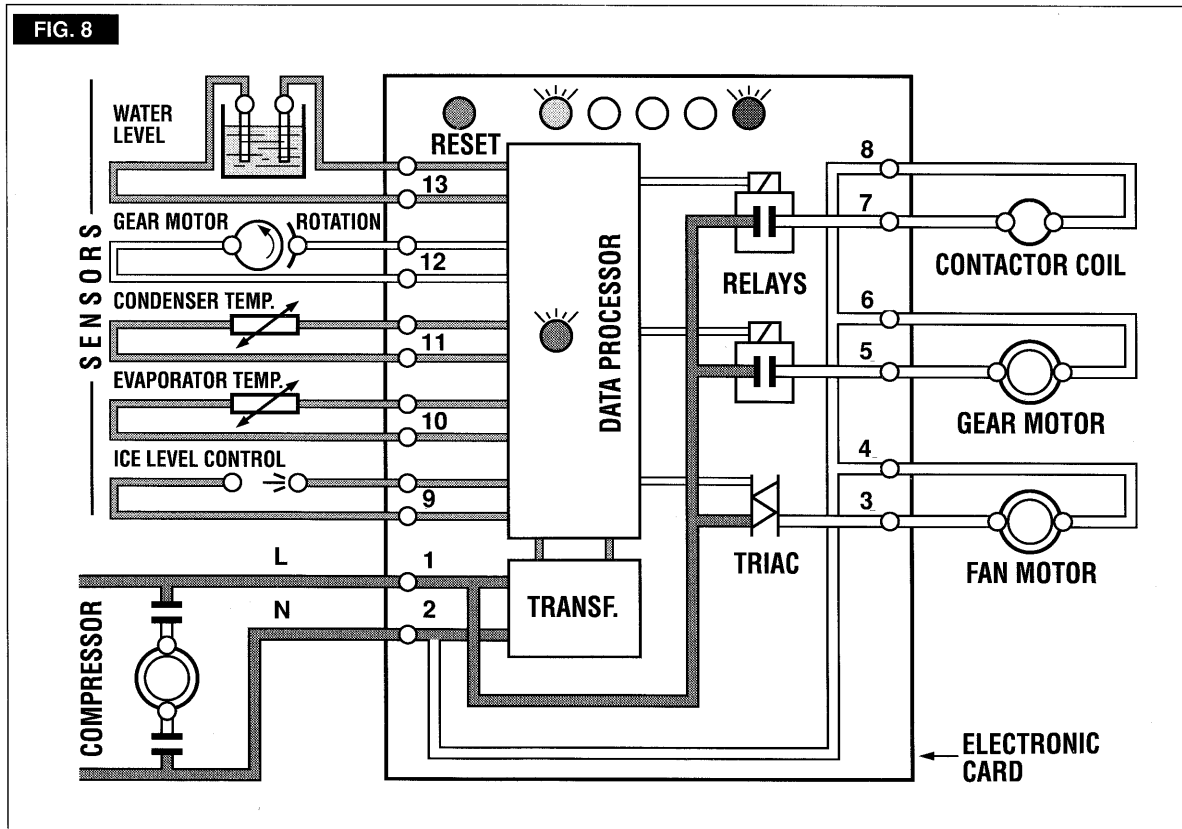

REFRIGERANT METERING DEVICE:

capillary tube

REFRIGERANT CHARGE (R 404 A)

	Air cooled	Water cooled
F 200	540 gr	410 gr
SF 300	750 gr	600 gr
SF 500	880 gr	820 gr
SF 1000	2200 gr	1300 gr

REFRIGERANT CHARGE (R 134 A)

	Air cooled	Water cooled
F100	320 gr	340 gr
F100C	300 gr	300 gr
F120	440 gr	380 gr

NOTE. Before charging the refrigerant system always check the type of refrigerant and quantity as specified on the individual ice machine dataplate. The refrigerant charges indicated are relatives to averages operating conditions.

OPERATING PRESSURES (With 21°C ambient temperature)

Discharge pressure:	F100/F100C/F120	F200/SF300-500-1000
Air cooled version	8 ÷ 9 bar	17 ÷ 18 bar
Water cooled version	8,5 bar	17 bar
Suction pressure:	0,5 bar	2.5 bar

COMPONENTS DESCRIPTION

A. EVAPORATOR TEMPERATURE SENSOR

The evaporator sensor probe is inserted into its tube well, which is welded on the evaporator outlet line, it detects the temperature of the refrigerant on the way out from the evaporator and signals it by supplying a low voltage current flow to the P.C. Board Micro-Processor.

According to the current received, the micro-processor let the ice maker to continue its operations. In case the evaporating temperature, after 10 minutes from the unit start-up, does not go below -1°C (30°F) due to shortage of refrigerant in the system or due to the excessive condensing temperature, the evaporator sensor signal reaching the microprocessor is such to stop immediately the unit operation, with the 5th Warning YELLOW LED that blinks.

B. FLOAT RESERVOIR WATER SENSOR SYSTEM.

This sensor system consist of two small stainless steel rods vertically fitted on the inner face of the reservoir cover and electrically connected to the low voltage circuit of the P.C. Board. When the cover of the reservoir is positioned in its place the tips of both the rods dip into the reservoir water and detects and signals its presence by making use of its electrical resistance.

NOTE. In the event of **shortage of water** in the reservoir or, in case the water used is too soft (de-mineralized) to cause greater resistance to the current flow (conductivity lower than $30\mu\text{S}$) this sensor system causes the **shutoff of the machine**, to protect it from running with an interrupted or inadequate water supply.
In this situation the **YELLOW LED** will glow to warn of the machine shutoff and the reason why.

C. CONDENSER TEMPERATURE SENSOR

The condenser temperature sensor probe, located within the condenser fins (air cooled version) or in contact with the tube coil (water cooled version) detects the condenser temperature variations and signals them by supplying current, at low voltage, to the P.C. BOARD.

In case the condenser temperature sensor detects a temperature at the condenser lower than $+1^{\circ}\text{C}$ (33°F) that signify that the ambient temperature is at the same value, therefore it is too low for the correct unit operation, the sensor signals to the microprocessor to stop immediately or to do not start the unit operations up to the moment that the ambient temperature will rise to more acceptable terms (10°C).

In the air cooled versions, in relation to the different current received, the micro processor of

the P.C. BOARD supplies, through a TRIAC, the power at high voltage to the fan motor so that it can cool the condenser and reduce its temperature.

In the event the condenser temperature rises and reaches 75°C (170°F) the current arriving to the micro processor is such to cause an immediate and total stop of the machine operation.

NOTE. To restart the unit after the shutoff caused by the condenser temperature sensor for any one of the two abnormal situations previously described, it is necessary to push the RE-SET button (after having remedied to the causes of unit stoppage) or to switch OFF and ON the power line main disconnect Switch.

D. GEAR MOTOR ROTATION AND SPEED SENSOR (Two on SF 1000 Model)

This safety device is housed on top of the Drive Motor (one per each motor on SF 1000 model) and detects - based on Hall Effect principle - the rotating speed and rotating direction of the drive Motor.

Should the rotating speed drop below 1300 r.p.m. the magnitude measured by this device is such to signal to the microprocessor to stop the unit and light-up the YELLOW LED. About the same reaction occurs when the drive motor will tend to rotate in the wrong direction (counterclockwise) situation that, if it occurs, will greatly affect all the freezer and gear reducer components.

NOTE. To restart the unit after the shutoff caused by this safety device, it is necessary first to eliminate the cause that has generated the intervention of the device and then press the RE-SET push button or switch OFF and ON the power line main disconnect switch.

E. ICE BIN LEVEL LIGHT CONTROL (Two on SF 1000 Model)

The electronic ice bin level control, located into the ice chute (one in each of the two ice chutes on SF 1000 model), has the function to stop the operation of the ice machine when the light beam between the light source and the sensor gets interrupted by the flake ice which accumulates in the chute.

When the light beam is interrupted the **RED LED** located in the front of the P.C. BOARD goes off; in case the light beam gets interrupted for as long as 10 seconds, the ice machine stops with the glowing-up of the **2nd YELLOW LED** to monitor the full ice bin situation.

The 10 seconds of delay prevents that any minimum interruption of the light beam due to the regular ice chuting through the ice chute may stop the operation of the unit.

As soon as the ice is scooped out (with the resumption of the light beam between the two infrared sensor of ice level control) the RED LED lights up and after 10 seconds the ice machine resume its operation with the simultaneous extinguishing the 2nd YELLOW LED.

F. P.C. BOARD (Data processor)

The **P.C. BOARD**, fitted in its plastic box located in the front of the unit, consists of two separated printed circuits one at high and the other at low voltage, protected by three fuses, integrated with a RE-SET button. Also it consists of five aligned **LEDS** monitoring the operation of the machine, of one extra monitoring **RED LED**, of a 8 keys **DIP SWITCH** and of input terminals for the leads of the sensor probes as well as input and output terminals for the leads of the ice maker electrical wires.

The P.C. BOARD is the brain of the system and it elaborates, through its micro processor, the signals received from the sensors in order to control the operation of the different electrical components of the ice maker (compressor, gear motor, etc.).

The five **LEDS**, placed in a row in the front of the P.C. BOARD, monitor the following situations:

- GREEN LIGHT**
Unit under electrical power

- YELLOW LIGHT**
Unit shut-off at full storage bin

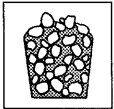
- YELLOW LIGHT**
Unit shut-off due to a **too lo-water level** into float tank

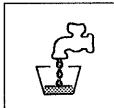
- RED LIGHT - BLINKING**
- 3' minutes stand by
- RED LIGHT - STEADY**
- Unit shut-off due to a **too hi-condensing temperature**
- Unit shut-off due to a **too lo-ambient temperature** <+1°C

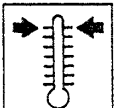
- YELLOW LIGHT**
- Unit shut-off due to the **wrong rotation direction** of gear motor
- Unit shut-off due to the **too lo speed of gear motor**
- Unit shut-off due to a **too hi-evaporating temp.** >-1°C after 10 min of operation

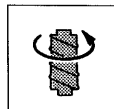

G. P.C. BOARD DIP SWITCH

The P.C. Board which controls the entire operation of the ice maker, has a **DIP SWITCH** with eight switching keys which allow to change the functions and set-up of some of the system controls as described in details herebelow.

The **first DIP SWITCH Key**, if positioned in **ON**, allows the skipping of the 3 minutes delay period at every start-up of the Ice Maker.

NOTE. To prevent that the unit be subject to startings and stoppings in rapid sequence it is strongly recommended to keep this key in **OFF position**.

The **2nd key** allows to make a rapid auto-diagnosis of the P.C. Board outputs to compressor, gearmotor and fan motor, by energizing them in rapid sequence (2 seconds) one at the time, to make sure of their operation.

DURING THE AUTOMATIC OPERATION OF THE ICE MAKER THIS KEY MUST BE SET IN OFF POSITION.

WARNING. This auto-diagnosis must be performed in the shortest possible time in order to avoid frequent startings and stoppings of the electrical components which may cause damages to their windings and controls.

The **key 3** is OF NO USE therefore it can be indifferently positioned in ON or OFF position without influencing at all the unit operations.

The **4th key** allows the switching of the unit reset from **manual (OFF setting)** to **automatic (ON setting)** when the machine operation has been cut-out by any of the safety control devices.

The **keys 5, 6 an 7** may be used to vary the temperature differntial determined by the condenser temperature sensor for the cut-in and cut-out of the fan motor, as indicated in the following table.

DIFFERENTIAL VARIATIONS OF CONDENSER TEMPERATURE SENSOR ACCORDING TO THE DIP SWITCH KEY SETTING COMBINATIONS			
5	6	7	DELTA T (°C)
ON	ON	ON	0,5
OFF	ON	ON	1,0
ON	OFF	ON	1,5
OFF	OFF	ON	2,0
ON	ON	OFF	2,5
OFF	ON	OFF	3,0
ON	OFF	OFF	3,5
OFF	OFF	OFF	4,0

The ideal combination which assure the best performance of the ice maker is the first one on the table, that gives a differential equal to 0,5°C from cut-in and cut-out of the fan motor to keep the condensing temperature and pressure as stright as possible.

The remaining **key 8** is used to modify the CUT OUT condensing temperature from 70°C **ON position**, for the air cooled versions, to 62°C **OFF position** for the water cooled versions.

H. INTERFACE P.C. BOARD (Only on SF 1000 Model)

Used only on SF 1000 model, it allows to elaborate the signal received from one of the two gear motor rotation/direction sensors as well as from one of the two ice bin level light controls transmitting it to the P.C. Board for the control of the unit operation.

In practical terms the Interface P.C. Board is equippepd by four INLET sockets (two for the drive motor rotation/direction sensors and two for the ice level controls) and two OUTLET plugs connected to the unit P.C. Board.

I. FLOAT RESERVOIR

The float reservoir consist of a plastic water pan on which is fitted a float valve with its setting screw. The float valve modulate the incoming water flow to maintain a constant water level in the reservoir, level that corresponds to the one in the freezing cylinder to ensure proper ice formation and fluidity.

On the inner side of the reservoir cover are fitted the two water level sensors which detects the presence or the shortage of water in the reservoir.

NOTE. It is very important to make sure of the correct fitting of the cover on the reservoir in order to enable the sensor to efficiently control the water situation avoiding undue shutoff interventions.

J. FREEZING CYLINDER or EVAPORATOR (Two on SF1000 Model)

The freezing cylinder is made of a stainless steel vertical tube on which exterior is wrapped around the cooling coil with the evaporating chamber and in its interior is located the auger which rotates on its vertical axis and it is maintained aligned by the top and bottom bearings. A water seal system is located in the bottom part of the freezer while at the top end is fitted the ice breaker.

The water constantly flowing into the cylinder bottom part, freezes into ice when in contact with the cylinder inner walls. The ice is then lifted up by the rotating auger and compacted and forced out by the ice breaker.

K. ICE BREAKER (Two on SF 1000 Model)

The ice breaker is fitted in the freezer upper part it has, on F 100C, F 100 and F 200 Model, two breaker teeth to break the ice and with its slanted shape from the rear tooth to the front one it compacts and forces the ice out in an horizontal way.

On the other models the ice breaker is made by several rectangular openings located on its external circumference where the ice is forced to pass through.

By undergoing this, the ice loses its excess of water content so it drops into the bin in hard dry bits of ice.

In the ice breaker it is housed the top bearing which is made of two rolls bearings positioned to withstand the auger axial and radial loads. This bearing is lubricated with a food grade - water resistant grease.

NOTE. It is advisable to check the conditions of both the lubricant grease and the bearings every six months.

L. DRIVE GEAR MOTOR (Two on SF 1000 Model)

This motoreducer is made of a single phase electric motor with permanent capacitor directly fitted on a gear box.

The drive motor rotor is kept aligned on its vertical axis by two ball bearings permanently lubricated. The gear case contains a train of three spur gears the first one of which is in fiber to limit the noise level. All the three gears are encased in case bearings and are covered by lubricant grease (MOBILPLEX IP 44).

Two seal rings, one fitted on the rotor shaft and the other on the output shaft keep the gear case sealed.

However the interior can be inspected and serviced by unbolting the two halves of the aluminium gear case housing.

M. FAN MOTOR (Air cooled version)

The fan motor is controlled through the P.C. BOARD and the TRIAC by the condenser temperature sensor. Normally it operates to draw cooling air through the condenser fins.

In cold ambient situation, the fan motor can run at intermittance as the condenser pressure must be kept between two corresponding head pressure values (13,5÷14,5 bars-190÷205 psig).

N. WATER REGULATING VALVE (Water cooled version)

This valve controls the head pressure in the refrigerant system by regulating the flow of water

going to the condenser.

As pressure increases, the water regulating valve opens to increase the flow of cooling water.

O. COMPRESSOR

The hermetic compressor is the heart of the refrigerant system and it is used to circulate and retrieve the refrigerant throughout the entire system.

It compresses the low pressure refrigerant vapor causing its temperature to rise and become high pressure hot vapor which is then released through the discharge valve.

ADJUSTMENT, REMOVAL AND REPLACEMENT PROCEDURES

NOTE. Read the instructions thoroughly before performing any of the following adjustment or removal and replacement procedure.

A. ADJUSTMENT OF THE EVAPORATOR WATER LEVEL

The correct water level in the freezing cylinder is about 20 mm. (1") below the ice discharge opening. Low water level causes excessive strain inside the freezer assembly due to a faster freezing rate.

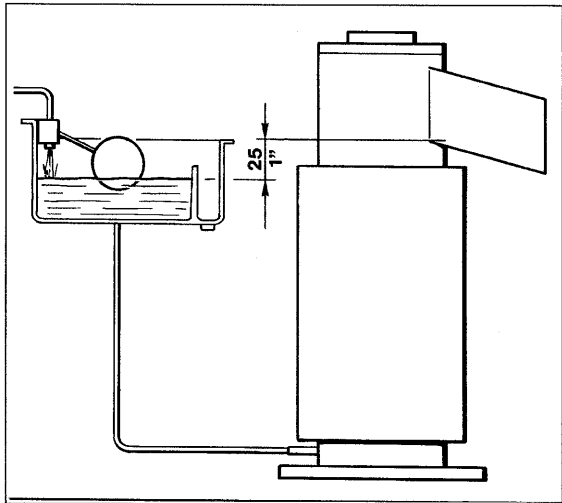

When the water level is above or below the correct one, adjustment can be performed to Raise or Lower the water level by raising or lowering at the measure required, the water reservoir and its mounting bracket.

1. To Raise the water level:

a. Loosen and remove the screw securing the mounting bracket of the water reservoir to the unit cabinet and raise the water reservoir to the correct level.

b. Thread the mounting screw in the corresponding hole and tighten it.

2. To Lower the water level follow the above indications to lower to the correct level the water reservoir assembly.

WARNING. Be sure the electrical power supply circuit breaker and the inlet water supply are OFF, before starting any of the following Removal and Replacement procedures as a precaution to prevent possible personal injury or damage to the equipments.

B. REPLACEMENT OF EVAPORATOR TEMPERATURE SENSOR

1. Remove the front/top panel.
2. Remove the insulation from the refrigerant tubing, connecting the freezer to the accumulator, to gain access to the sensor probe well and be able to pull out from this well the sensor probe.
3. Trace the condenser sensor terminal plug on the rear side of the control box and remove it from its socket by carefully pulling out the terminal plug securing clip.
4. To install the replacement evaporator sensor follow the above steps in reverse.

C. REPLACEMENT OF CONDENSER TEMPERATURE SENSOR

1. Remove the front /top panel and on MF 61 model even the right side panel.
2. Trace the condenser sensor probe located within the condenser fins on air cooled version and withrow it.
On water cooled version remove it by opening the plastic strap (reusable) securing the probe to the refrigerant liquid line.
3. Trace the condenser sensor terminal plug on the rear side of the control box and remove it from its socket by carefully pulling out the terminal plug securing clip.
4. To install the replacement condenser sensor follow the above steps in reverse.

D. REPLACEMENT OF THE ICE LEVEL LIGHT CONTROL

1. On F 100C, F 100, F 200, SF 300 and SF 500 remove the front/top panel, while on SF 1000 remove the front and rear panels.
2. Trace the ice level light control terminal plug (black and with four terminal pins) on the rear side of the control box and draw it out from its socket by carefully slackening the fastening tie.

3. Remove, withdrawing them from the holes pierced on the sides facing each other of the plastic ice chute, the two ice level light controls. Press their rubber holders on their external edge/rim paying attention to do not damage the infrared LED.

4. To install the replacement ice level light control follow the above steps in reverse.

E. REPLACEMENT OF THE GEAR MOTOR ROTATION AND SPEED SENSOR

1. On F 100C, F 100, F 200, SF 300 and SF 500 remove the front/top and side/rear panels, and on SF 1000 remove the front, top and left side panels.

2. Unloose the three screws securing the plastic cover to the gear motor speed sensor housing and remove it.

3. Unloose the two screws securing the sensor to the plastic housing and withdraw it from its seat.

4. Trace the gear motor speed sensor terminal plug on the rear side of the control box and draw it out from its socket by carefully slackening the fastening tie.

5. To install the replacement gear motor rotation and speed sensor follow the above steps in reverse.

F. REPLACEMENT OF THE RESERVOIR WATER LEVEL SENSOR

1. Remove the front /top panel.

2. Unloose the two nuts securing the wire leads to the two water level sensor rods located on the water reservoir plastic cover.

3. Trace the water level sensor terminal plug on the rear side of the control box and draw it out from its socket by carefully slackening the fastening tie.

4. To install the replacement water level sensor follow the above steps in reverse.

G. REPLACEMENT OF P.C. BOARD

1. Remove front/top panel.

2. Remove all sensor terminal plugs, located on the rear side of P.C. Board, by carefully releasing them out from their sockets clips.

3. Disconnect the terminal board connection plug from the rear side of P.C. BOARD then unloose the four screws holding the same to the plastic control box and remove it.

4. To install the replacement P.C. BOARD follow the above steps on reverse.

H. REPLACEMENT OF THE ICE SPOUT

1. Remove the front/top panel.

2. Unloose the wing nut and take off the ice chute from the ice spout paying attention to avoid to damage the ice level light control.

3. Slacken and remove the two straps that hold tight the polystyrene insulations against the freezer upper part.

4. On the model F 100C, F 100 and F 200 unthread the S.S. spout from the brass casting one while on the other models unthread the bolts securing it to the ice breakers.

5. On model F 100C, F 100 and F 200 unloose and remove the two screws and separate the spout casting from the freezer cylinder.

NOTE. On model F 100C, F 100 and F 200 inspect the spout gasket and replace it if torn, cut or worn otherwise retain it to be used again.

6. To install the replacement spout follow previous steps in reverse.

I. REPLACEMENT OF THE AUGER, WATER SEAL, BEARINGS AND COUPLING

1. Remove the front/top panel.

2. Follow the steps at item H to remove the ice spout.

3. On model F100/F200 unloose and remove two screws and washers holding tight the spout bracket to the freezing cylinder.

On models SF300/500/1000 unloose and remove the four bolts securing the ice breaker to the upper flange of the evaporator.

4. On model F100/F200 grasp the wire cap hook at the top for the freezer and pull out the auger, attached cap and ice breaker from the top for the freezer.

On models SF300/500/1000 with two flat screwdrivers insert them on the space between the icebreaker and the upper flange and by tilting them lift the icebreaker and auger assembly.

Grasp the icebreaker and remove the icebreaker and auger assembly by lifting them from the evaporator.

NOTE. If the auger cannot be pulled out, proceed to steps 10 and 11 of this paragraph, to gain access to the auger bottom. Then, with a rowhide mallet or placing a piece of wood on the bottom end of the auger, tap this bottom to break loose the auger and be able then to pull it out as in step 4 above.

5. On model F 100C, F 100 and F 200, with a circlip plier, remove the retaining ring and cap hook from the ice breaker while, on the superflaker models, remove the plastic cap using a screwdriver as a lever.
6. Unloose and remove cap screw and remove the ice breaker from the auger.
7. Clean away the old grease from the interior of the ice breaker and inspect the conditions of the O ring; if torn or worn replace it.
8. Inspect the bearing pressed into the top of the ice breaker and if worn do not hesitate to replace it.

WARNING. The top bearing assembly works in critical conditions for what concern its lubrication status as it is housed in the ice breaker where the formation of a great rate of condensation is usual. Therefore it is important to apply on it an ample coating of Food grade Waterproof Grease before installing the breaker and cap hook in place.

9. Slide off from the auger bottom the upper half of the water seal.

NOTE. Any time the auger is removed for replacement or inspection use extra care in handling the water seal parts, so no dirt or foreign matters are deposited on the surfaces of the seal. If there is any doubt about the effectiveness of the water seal or O ring do not hesitate to REPLACE THEM.

10. Unloose and remove the three/four bolts and lockwashers which attach the freezer assy to the aluminium adaptor.

11. Raise the freezer assy of the adaptor, secur it out of the way to allow room to work. Using a suitable lenght and size wooden dowel or stick inserted through the top of the open freezer, tap the lower half of the water seal and the lower bearing out the bottom of the freezer.

12. On the superflaker models, with two screwdriver as a lever, remove from the bottom of the freezer assy the lo bearing brass holding ring.

NOTE. It is good practice to replace th water seal assy and both the top and the bottom bearings any time the auger is removed.

To facilitate this, it is available a service Kit which includes besides the above mentioned parts, the ice breaker O ring and a tube of food grade waterproof grease.

13. Reach throught the adaptor and remove the coupling parts.

14. Check both the coupling halves for chipping and wear and do not hesitate to replace them.

15. Install the bottom bearing into its brass housing paying attention to have the white plastic ring facing up.

16. Install the upper bearing into the ice breaker starting by the radial portion that must be fitted with the flat surface facing up.

17. Apply some lubricant (grease) on the upper surface the install the rollers cage with the smaller openings of the same facing up so to leave a small gap between plastic cage and flat surface of the botton portion of the bearing (see drawing).

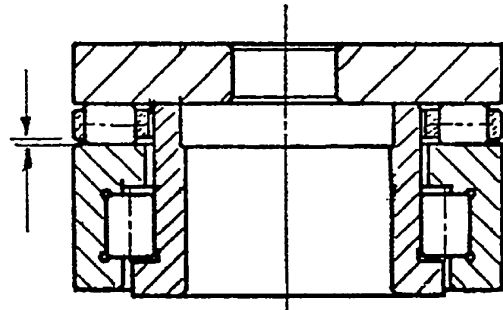

18. Apply some move lubricant then place the S.S. trust washer.

19. After to have replace the O ring into the ice breaker fit the same on top of the auger and secure it with the top bolt.

20. Install the auger/icebreaker into the evaporator following the previous steps in reverse.

J. REPLACEMENT OF THE GEAR MOTOR ASSY

1. On F 100C, F 100, F 200, SF 300 and SF 500 remove the front/top and side/rear panels and on SF 1000 remove the front, top and left side panels.

2. Remove the three/four bolts and washers securing the gear reducer base to the unit chassis,

then remove bolts and lockwashers which attach the bottom of the aluminium adaptor to the gear reducer case cover.

3. Follow the steps of item E to remove the gear motor rotation and speed sensor.
4. Trace and disconnect the electric wires leads of the drive motor. Lift and remove the entire gear motor assembly.
5. To install the replacement gear motor assy follow the above steps in reverse.

K. REPLACEMENT OF FAN MOTOR

1. Remove the front/top and side/rear panels on models F 100C, F 100, F 200, SF 300 and SF 500 and the front panel on model SF 1000.
3. On the models F 100C, F 100, F 200, SF 300 and SF 500 remove the bolts securing the fan motor bracket to the cabinet base and then remove the assembly.
On model SF 1000 unloose, with an allen key, the screw securing the fan blade hub to the fan motor shaft then unscrew the bolts holding the fan motor to its protection grid.
4. To install the replacement fan motor follow the above steps in reverse.

NOTE. When installing a new fan motor check that the fan blades do not touch any surface and move freely.

L. REPLACEMENT OF DRIER

1. Remove the front/top and side/rear panels on models F 100, F 100 C, F 200, SF 300 and SF 500 and the front panel on model SF 1000.
2. Recover the refrigerant from the system and transfer it in a container so to reclaim or recycle it.
3. Unsolder the refrigerant lines from the two ends of the drier (the capillary tube from one side on F 100, F 100C and F 200).
4. To install the replacement drier remove factory seals and solder the refrigerant lines and the capillary tube taking precautions to NOT OVERHEAT the drier body.
5. Thoroughly evacuate the system to remove moisture and non condensable after drier replacement.

6. Charge the system with refrigerant 22 by weight (see data plate of machine) and check for leaks.

7. Replace panels previously removed.

M. REPLACEMENT OF THE FREEZING CYLINDER

1. Follow the steps at item H to remove the ice spout.
2. Remove the clamp fastening the water hose to the water inlet port of the freezer assy. Place a water pan under this water inlet port then disconnect the water hose and collect all water flowing from freezer and from water hose.
3. Withdraw the evaporator sensor probe from the its holder as stated in item B.
4. Recover the refrigerant from the system and transfer it in a container so to reclaim or recycle it.
5. Unsolder and disconnect the capillary tube and the accumulator/suction line assy from the outlet line of the freezing cylinder.
6. Remove the three/four bolts and washers securing the gear reducer base to the unit chassis, then remove bolts and lockwashers which attach the bottom of the aluminium adaptor to the gear reducer case cover.
7. Lift the freezer up and off the gear motor assembly, then if necessary remove the aluminium adaptor by removing the three mounting screws and lockwashers.

NOTE. Always install a replacement drier whenever the sealed refrigeration system is open.
Do not replace the drier until all other repairs or replacements have been completed.

8. To install the replacement evaporator follow the above steps in reverse.

NOTE. Thoroughly evacuate the system to remove moisture and non condensables after evaporator replacement.

N. REPLACEMENT OF AIR COOLED CONDENSER

1. Remove front/top and side/rear panels on models F 100, F 100C, F 200, SF 300 and top SF 500 and the front and right side panel on model SF 1000.

2. Remove from the condenser fins the condenser ambient temperature sensor probes.
3. Remove the two bolts attaching the condenser to the base.
4. Recover the refrigerant from the system and transfer it in a container so to reclaim or recycle it.
5. Unsolder the refrigerant lines from the condenser and remove it from the unit.

NOTE. Always install a replacement drier whenever the sealed refrigeration system is open. Do not replace the drier until all other repairs or replacements have been completed.

6. To install the replacement condenser follow the above steps in reverse.

NOTE. Thoroughly evacuate the system to remove moisture and non condensables after condenser replacement.

O. REPLACEMENT OF WATER COOLED CONDENSER

1. Remove front/top and side/rear panels on models F 100, F 100C, F 200, SF 300 and SF 500 and the front and right side panel on model SF 1000.
2. Remove the condenser temperature sensor probes from condenser.
3. Remove bolts which secure the condenser to the unit base.
4. Remove the corbin clamps and disconnect the plastic hoses from the water cooled condenser.
5. Recover the refrigerant from the system and transfer it in a container so to reclaim or recycle it.
6. Unsolder the refrigerant lines from the condenser and remove it from the unit.

NOTE. Always install a replacement drier whenever the sealed refrigeration system is open. Do not replace the drier until all other repairs or replacements have been completed.

7. To install the replacement condenser follow the above steps in reverse.

NOTE. Thoroughly evacuate the system to remove moisture and non condensables after condenser replacement.

P. REPLACEMENT OF WATER REGULATING VALVE (WATER COOLED MODELS)

1. Remove the front/top and side/rear panels on models F 100, F 100C, F 200, SF 300 and SF 500 and left side panel on model SF 1000.
2. Close the shut-off valve on the water supply line and disconnect it at the rear of the flaker.
3. Remove corbin clamp and disconnect the water hose from the outlet of water regulating valve.
4. Unloose the nut securing the water regulating valve to the unit frame.
5. Recover the refrigerant from the system and transfer it in a container so to reclaim or recycle it.
6. Trace the water regulating valve capillary tube and unsolder its end from the refrigerant line then remove it from the unit.

NOTE. Always install a replacement drier whenever the sealed refrigeration system is open. Do not replace the drier until all other repairs or replacements have been completed.

7. To install the replacement water regulating valve follow the above steps in reverse.

NOTE. Thoroughly evacuate the system to remove moisture and non condensables after water regulating valve replacement.

NOTE. The water flow that passes through the valve can be adjusted by means of the valve setting stem in order to have a condensing pressure of 14 bars (195 psig).

Q. REPLACEMENT OF COMPRESSOR

1. Remove front/top and side/rear panels on models F 100, F 100C, F 200, SF 300 and SF 500 and the front panel on model SF 1000.
2. Remove the cover and disconnect the electrical leads from the compressor junction box.
3. Recover the refrigerant from the system and transfer it in a container so to reclaim or recycle it.
4. Unsolder and disconnect both the suction line and the discharge line from the compressor.

5. Remove the four compressor mounting bolts and the compressor from the unit base.

6. Unsolder suction and process header from compressor and retain it to be used on new compressor.

NOTE. Always install a replacement drier whenever the sealed refrigeration system is open.
Do not replace the drier until all other repairs or replacements have been completed.

7. To install the replacement compressor follow the above steps in reverse.

NOTE. Thoroughly evacuate the system to remove moisture and non condensables after compressor replacement.

WIRING DIAGRAM F 100 C W

LEGENDA

MV	Ventilatore	Fan
MR	Motoriduttore	Gearmotor
MC	Compressore	Compressor
SC	Scheda elettronica	Electronic card
SL	Livello acqua	Water Level
SH	Sonda rotazione	Rotation probe
SS	Sonda condensatore	Condenser probe
ST	Sonda evaporatore	Evaporator probe
SO	Sistema ottico	Fotoswitch system
CA	Cavo alimentazione	Power cable
CT	Connettore di testa	Terminal for cables
F	Fissacavo	Lock-Cable

ON OFF	TARATURA SWITCH	SWITCH SET
1	▲ RITARDO 3 MIN. (OFF = INSERITO)	⊗ DELAY 3 MIN. (OFF = INSERT)
2	▲ AUTOTEST (OFF = INSERITO)	⊗ SELFTEST (OFF = INSERT)
3	▲ SENSO ROTAZIONE MOTORIDUTTORE	⊗ GEARMOTOR ROTATION CONTROL
4	▲ RIPRISTINO (OFF = AUTOMAT.)	⊗ RESET (OFF = AUTOM.)
5	} DIFFERENZIALE VENTILATORE	⊗ FAN DIFFERENTIAL
6		
7		
8	■ NON UTILIZZATO	○ NOT USED

COLORI CAVI CABLE COLOR

m	= marrone	/brown
bc	= blu chiaro	/light blue
gv	= giallo-verde	/yellow-green

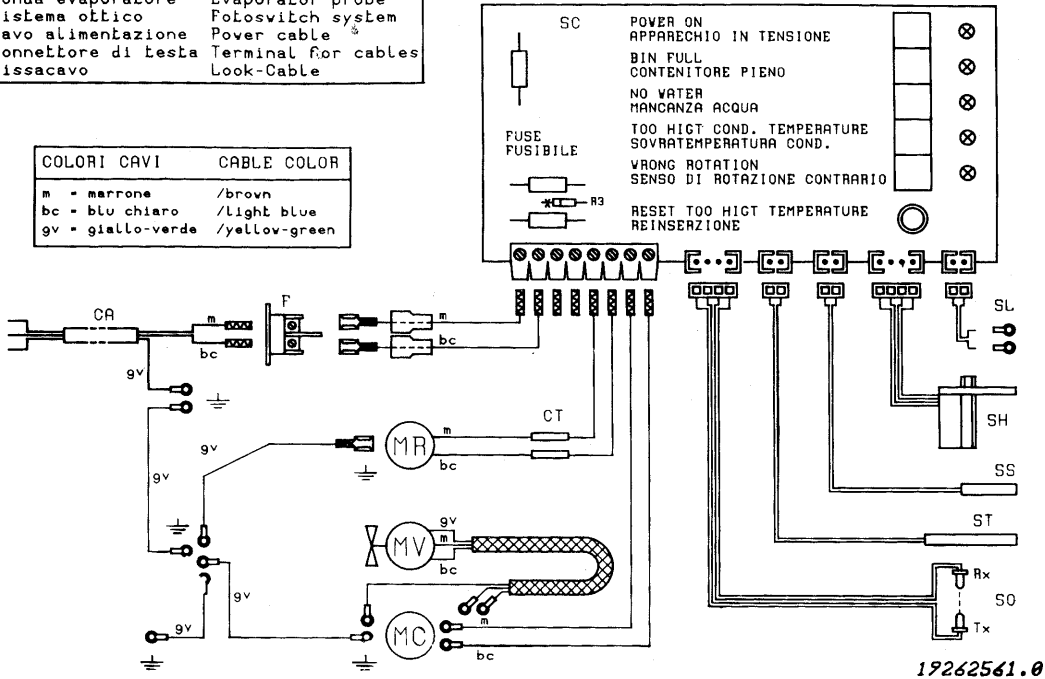

19262561.0

WIRING DIAGRAM F 100 C

LEGENDA

MV	Ventilatore	Fan
MR	Motoriduttore	Gearmotor
MC	Compressore	Compressor
SC	Scheda elettronica	Electronic card
SL	Livello acqua	Water Level
SH	Sonda rotazione	Rotation probe
SS	Sonda condensatore	Condenser probe
ST	Sonda evaporatore	Evaporator probe
SO	Sistema ottico	Fotoswitch system
CA	Cavo alimentazione	Power cable
CT	Connettore di Testa	Terminal for cables
F	Fissacavo	Lock-Cable

ON OFF	TARATURA SWITCH	SWITCH SET
1	▲ RITARDO 3 MIN. (OFF = INSERITO)	⊗ DELAY 3 MIN. (OFF = INSERT)
2	▲ AUTOTEST (OFF = INSERITO)	⊗ SELFTEST (OFF = INSERT)
3	▲ SENSO ROTAZIONE MOTORIDUTTORE	⊗ GEARMOTOR ROTATION CONTROL
4	▲ RIPRISTINO (OFF = AUTOMAT.)	⊗ RESET (OFF = AUTOM.)
5	} DIFFERENZIALE VENTILATORE	⊗ FAN DIFFERENTIAL
6		
7		
8	■ NON UTILIZZATO	○ NOT USED

COLORI CAVI CABLE COLOR

m	= marrone	/brown
bc	= blu chiaro	/light blue
gv	= giallo-verde	/yellow-green

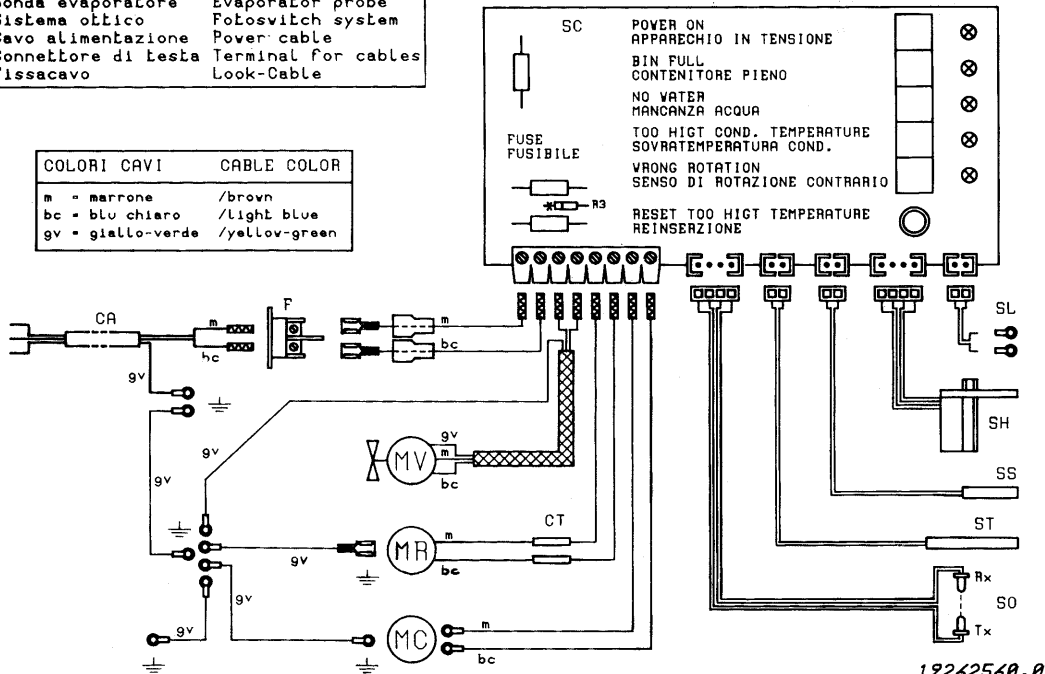

19262560.0

WIRING DIAGRAM F 100 - F 120 - F 200
AIR AND WATER COOLED
SINGLE PHASE

- B - WHITE
- G - GREY
- N - BLACK
- A - BLUE
- M - BROWN
- GV - YELLOW GREEN

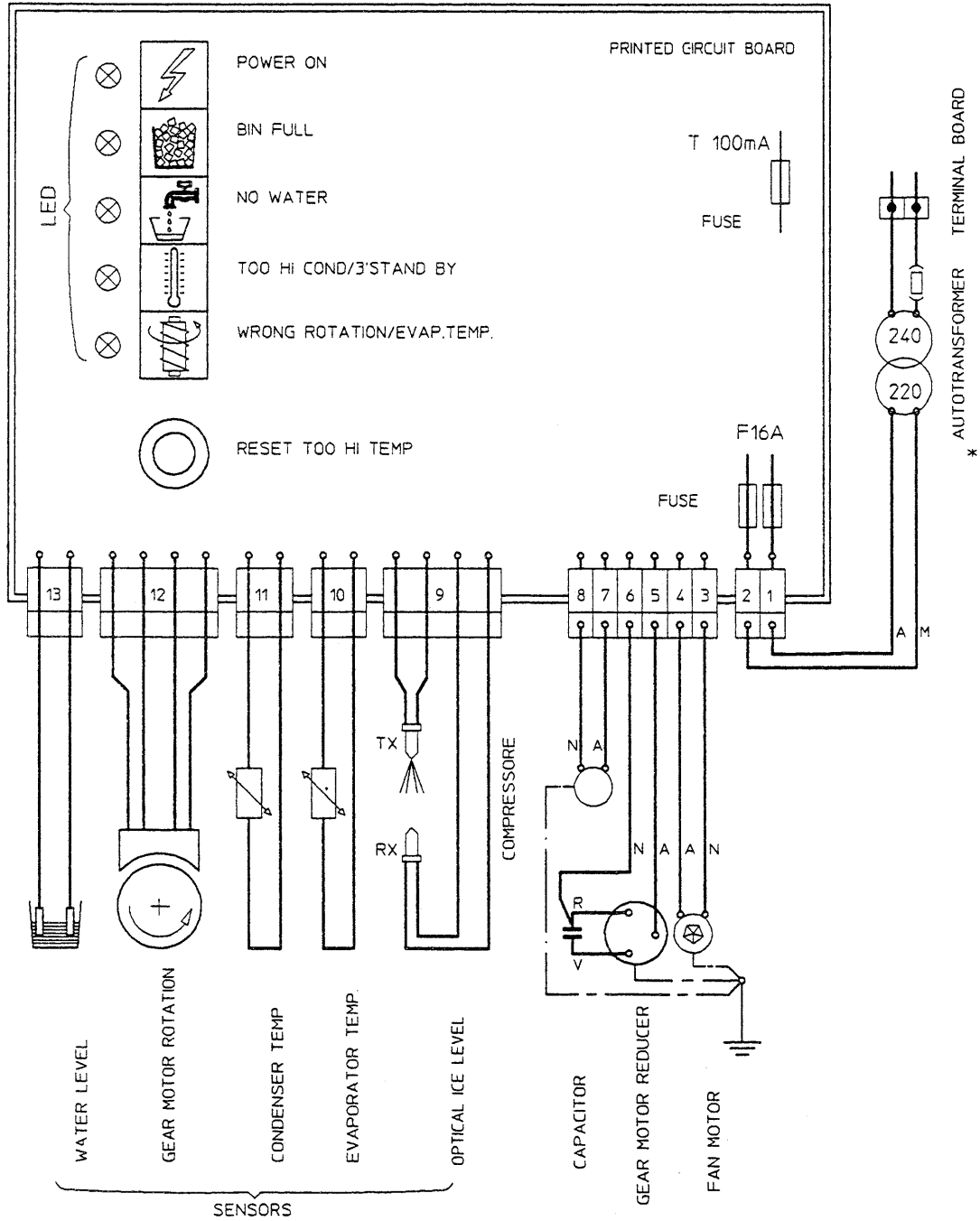

⊗ JUST FOR AIR COOLED UNIT

* USED ONLY UNIT AT 240V

WIRING DIAGRAM SF 300 - SF 500

AIR AND WATER COOLED

SINGLE PHASE

- B - WHITE
- G - GREY
- N - BLACK
- A - BLUE
- M - BROWN
- GV - YELLOW GREEN

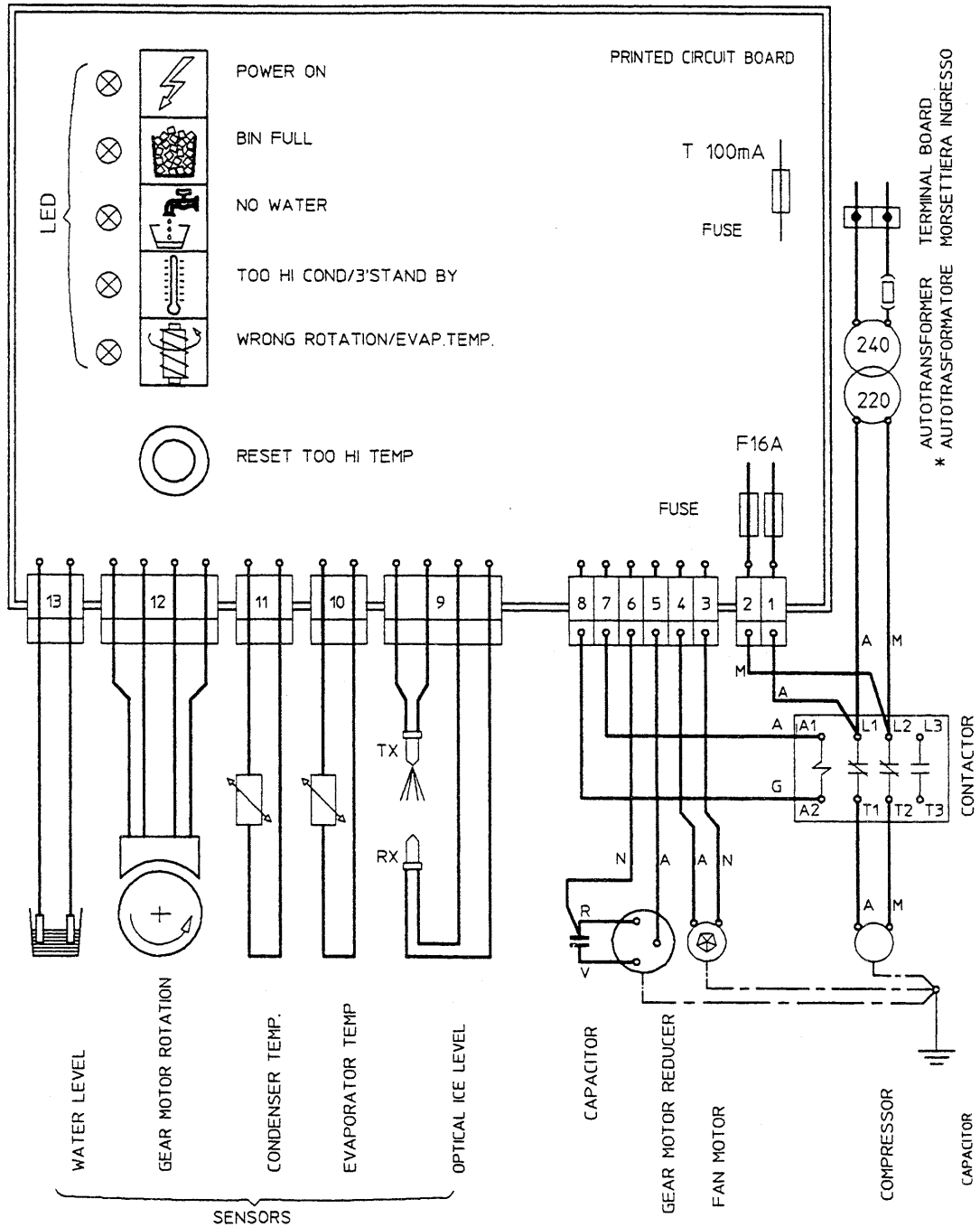

⊗ JUST FOR AIR COOLED UNIT

* USED ONLY UNIT AT 240V

WIRING DIAGRAM SF 500

AIR AND WATER COOLED THREE PHASE

- B - WHITE
- G - GREY
- N - BLACK
- A - BLUE
- M - BROWN
- GV - YELLOW GREEN

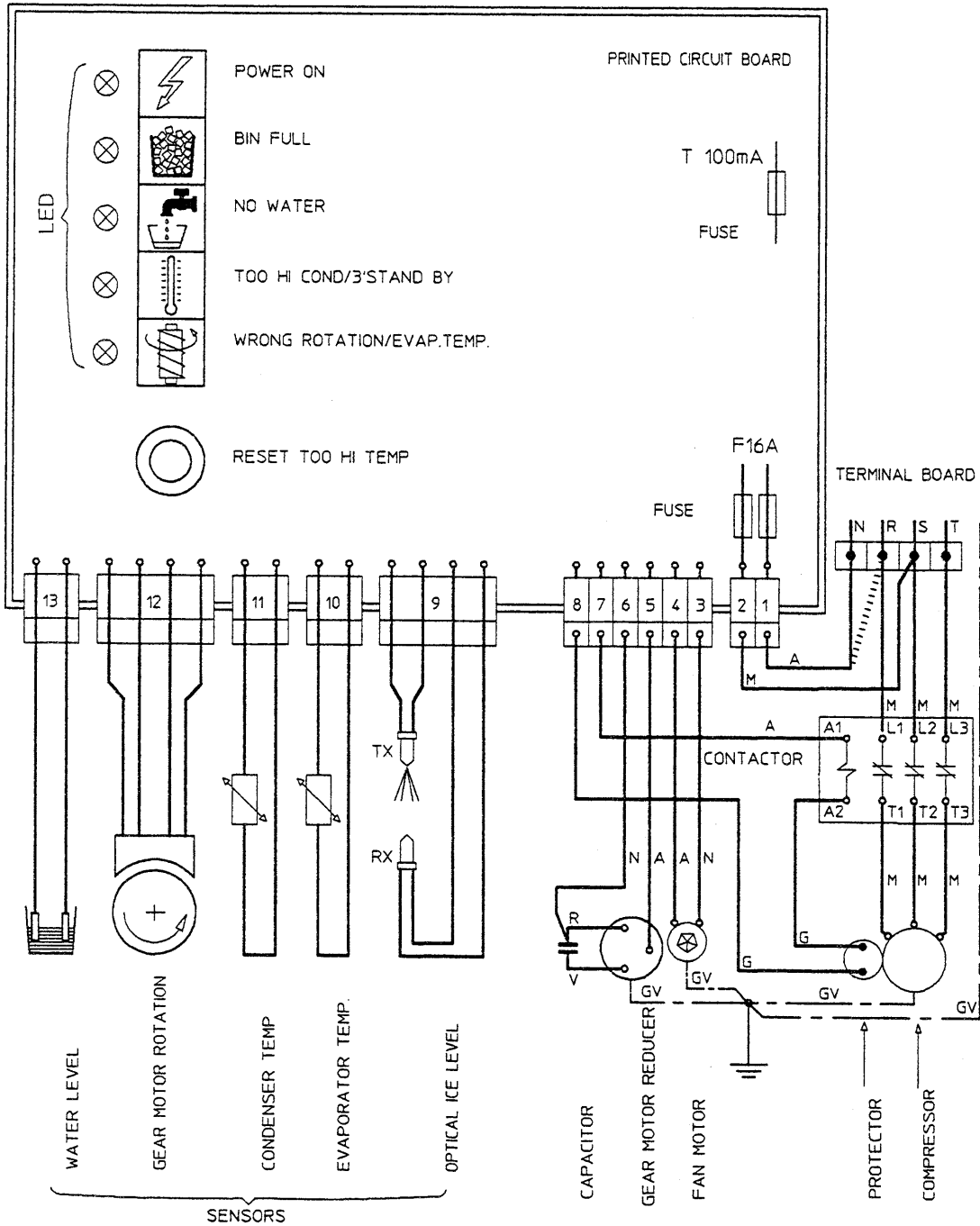

⊗ JUST FOR AIR COOLED UNIT

CONNECTION REPLACES NEUTRAL FOR MODEL 220/50-60/3

SERVICE DIAGNOSIS

SYMPTON	POSSIBLE CAUSE	SUGGESTED CORRECTION
Unit will not run No LED lighted-up Bin full yellow LED glows Shortage of water yellow LED glows Red-alarm LED glows Reverse rotation yellow LED blinks Shortage or lack of refrigerant Reverse rotation yellow LED glows	Blown fuse in P.C.Board	Replace fuse & check for cause of blown fuse
	Master switch in OFF position	Turn switch to ON position
	Inoperative P.C.Board	Replace P.C.Board
	Loose electrical connections	Check wiring
	Inoperative or dirty ice level control	Replace or clean ice level control
	Shortage or too soft water	See remedies for shortage of water or install a mineral salt metering device
Red-alarm LED glows	High head pressure	Dirty condenser. Clean INOPERATIVE fan motor. Replace
	Ambient temperature too low	Move unit in warmer location
Reverse rotation yellow LED blinks Shortage or lack of refrigerant	Too hi evap. temperature	Check and charge refrigerant system
	Gear motor tends to run on reverse Too low gear motor rotating speed	Check stator winding and capacitor
Check rotor bearings, freezer bearings and interior of freezer for scores. Replace whatever worn or damaged.		
Compressor cycles intermittently	Low voltage	Check circuit for overloading Check voltage at the supply to the building. If low, contact the power company
	Non-condensable gas in system	Purge the system
	Compressor starting device with loose wires	Check for loose wires in starting device
Low ice production	Capillary tube partially restricted	Blow charge, add new gas & drier, after evacuating system with vacuum pump
	Moisture in the system	Same as above
	Low water level in the freezer	Adjust to approx 20 mm below ice spout
	Shortage of refrigerant	Check for leaks & recharge
	Pitted or stained auger surface	Clean or replace auger

SERVICE DIAGNOSIS

SYMPTON	POSSIBLE CAUSE	SUGGESTED CORRECTION
Wet ice	Ambient temperature too high Under or overcharge of refrigerant High water level in the freezer Faulty compressor	Move unit to cooler location Recharge with correct quantity Lower to approx. 20 mm below ice spout Replace
Machine runs but makes no ice	Water not entering in the freezer Drive motor or gear stripped Moisture in the system	Air lock in feed line to freezer. Vent it Clogged feed line to freezer. Clean it Check repair or replace Purge, replace drier and re-charge
Water leaks	Water seal leaking Water feed line to freezer leaking Float valve not closing Rubber spout gasket leaking	Replace water seal Check and fasten hose clamp Check and adjust float valve setting screw Remove spout and replace gasket
Excessive noise or chattering	Mineral or scale deposit on auger and inner freezer walls Low suction pressure Water feed line to freezer clogged Low water level into freezer Worn freezer bearings	Remove and manually polish auger and inner walls of freezer barrel using emery paper Add refrigerant to rise suction pressure Vent and clean it Adjust to approx. 20 mm below ice spout Check and replace
Gear motor noise	Worn rotor bearings Shortage or poor lubricant in gear case Gear case bearings and racers worn out	Check and replace Check for proper lubr. opening gear case. Top of gears must be covered with lubr. Check and replace worn parts
Shortage of water	Strainer at water inlet fitting clogged Float reservoir water nozzle clogged-up	Remove strainer and clean Remove float valve and clean nozzle

MAINTENANCE AND CLEANING INSTRUCTIONS

A. GENERAL

The periods and the procedures for maintenance and cleaning are given as guides and are not to be construed as absolute or invariable. Cleaning, especially, will vary depending upon local water and ambient conditions and the ice volume produced; and, each icemaker must be maintained individually, in accordance with its particular location requirements.

B. ICEMAKER

The following maintenance should be scheduled at least two times per year on these icemakers.

1. Check and clean the water line strainer.
2. Remove the cover from the float reservoir - care to do not damage the two water sensors - and depress the float to make sure that a full stream of water enters into the reservoir.
3. Check that the icemaker is levelled in side to side and in front to rear directions.
4. Check that the water level in the water reservoir is below the overflow but high enough that it does not run out of the spout opening.

5. Clean the water system, water reservoir and the interior of freezing cylinder using a solution of Acid Citric. Refer to procedure C cleaning instructions and after cleaning will indicate frequency and procedure to be followed in local areas.

NOTE. *Cleaning requirements vary according to the local water conditions and individual user operation.*

6. If required, polish the two sensor rods secured to the float reservoir cover, heavy scale sediment on them can be removed with the help of a bit Cleaner plain.
7. With the ice machine and fan motor OFF on air cooled models, clean condenser using vacuum cleaner, whisk broom or non metallic brush taking care to do not damage the condenser/ambient temperature sensor.
8. Check for water leaks and tighten drain line connections. Pour water down bin drain line to be sure that drain line is open and clear.

9. Check the ice level control sensor to test shut-off. Put your hand between the light source and the receiver so to cut off the light beam for at least 10 seconds.

This should cause the immediate extinguishing of the RED LED located in the front face of P.C. Board and, 10 seconds later the total stopping of the ice maker with the simultaneous light up of the Full Bin Yellow LED.

Within few seconds from the removal of the hand from between the sensor lights the ice maker resume its operation.

NOTE. *The ice level control uses devices that sense light, therefore they must be kept clean enough so they can "see". Every month clean/wipe the sensing "eyes" with a clean soft cloth.*

10. Check for refrigerant leaks and for proper frost line, which should frost as far as approx. 20 cm (8") from the compressor. When doubtful about refrigerant charge, install refrigerant gauges on corresponding Schröder valves and check for correct refrigerant pressures. (See Operating pressure at page 23 of this manual).

11. Check that fan blades move freely and are not touching any surfaces.

12. Remove the retaining ring and the hook and cap from the top of the freezer assembly then inspect the top bearing, wipe clean of all grease and apply a coating of food grade water proof grease.

NOTE. *It is recommended to use only food grade and waterproof grease to lubricate the freezer top bearing.*

13. Check the quality of ice. Ice flakes should be wet when formed, but will cure rapidly to normal hardness in the bin.

NOTE. *It is not abnormal for some water to emerge from the ice spout with the flaker ice.*

C. CLEANING INSTRUCTIONS OF WATER SYSTEM

1. Switch OFF the Master disconnect switch on the power line.
2. Remove all ice stored in the bin to prevent it from getting contaminated with the cleaning solution.

3. Shut close the water shutoff valve on water line.
4. Remove the top panels to gain access to the water reservoir.
5. Remove the float reservoir cover and with a piece of copper wire shunt the two water level sensors.
6. Place a water pan under the freezer water inlet port, disconnect the water hose from this port and allow the water from the freezer to flow into the pan previously positioned. Then refit the water hose to the freezer water inlet port.
7. Prepare the cleaning solution by diluting in a plastic container two or three liters of warm water (45°-50°C) with a 0,2-0,3 kg of ACID CITRIC.
8. Switch ON the Master switch to start the unit then pour the cleaning solution into the float reservoir.
9. Wait for about three minutes for the unit to start operating, then continue to slowly pour the cleaning solution into the water reservoir taking care to maintain the level just below the overflow.

NOTE. *The ice made with the cleaning solution is slushy and coloured also, it may tend to loose fluidity creating some resistance in being elevated and extruded; this situation can be heard by the creaking noise made by the ice.
Should this occur it is recommended to stop for few minutes the ice machine in order to allow the ice in the freezer to partially melt.*

10. When all the cleaning solution has been used up, open the water shutoff valve to allow new fresh water to flow into the reservoir. Let the unit to continue to run until the ice resumes the normal colour and hardness.
11. Stop the icemaker and pour warm water on the ice deposited into the storage bin to melt it up, then, with a sponge moisted with a sanitizing solution, wipe clean all the bin interior surfaces.

NOTE. *DO NOT use ice produced with the cleaning solution. Be sure none remains in the bin.*

12. Remove the copper wire used to shunt the two sensors for the water level and reposition correctly the cover on the float reservoir.
13. Wipe clean and rinse the inner surfaces of the storage bin.

REMEMBER. *To prevent the accumulation of undesirable bacteria it is necessary to sanitize the interior of the storage bin with an anti-algae disinfectant solution every week.*

Castel MAC SpA

Via del Lavoro, 9 C.P. 67
I - 31033 Castelfranco Veneto (TV) Italy
Tel. (0423) 738455 - Fax (0423) 722811
E-mail: service@castelmac.it
Web-site: www.castelmac.it

Cod. 71503382/0-GB - Rev. 001 - 01/2001

