

MONTERINGSINSTRUKTION PUMPBYTE WD-6

VID BYTE TILL FIR 2241 (OMBYGGNADSSATS WD741.4502)

PUMP SEDD OVANIFRÅN

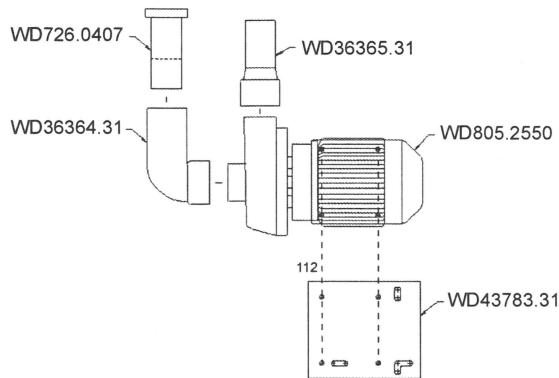

Vid behov monteras även rörmuffen WD726.0407.

Muffen och eventuellt även gummiböjen kan behöva kapas en bit.

Om undre spoltrycket blir för högt efter installationen kan den medlevererade strypbrickan monteras vid den undre spolarmsinfästningen.

Detta gäller maskiner tillverkade 1991 t.o.m maskinnr. 012966.

Brickan placeras med den stora diametern uppåt och spännes fast med lagertappen.

På maskiner tillverkade före 1991 ska den medskickade stryphylsan monteras i stamrörets anslutningsände enligt bild.

Adapter WD43783.31 används ej om maskinen har pump FIR 0251 monterad.

Dessa pumpar är grå till färgen (motor och pumphus) och användes mellan 1997 och 1999.

Är denna pump monterad måste ett nytt fästhål borrar enligt bild.

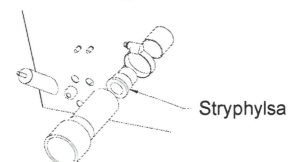
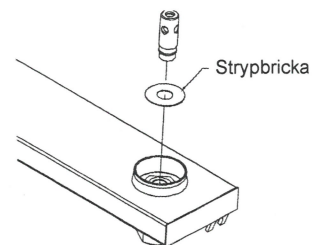
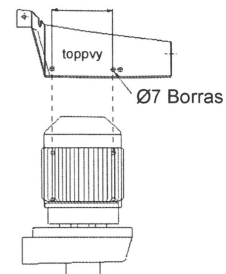
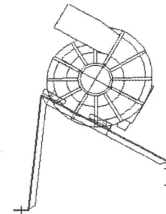

MOUNTING INSTRUCTION PUMP REPLACEMENT WD-6

REPLACEMENT INTO FIR 2241 (REBUILDING KIT WD741.4502)

TOPVIEW

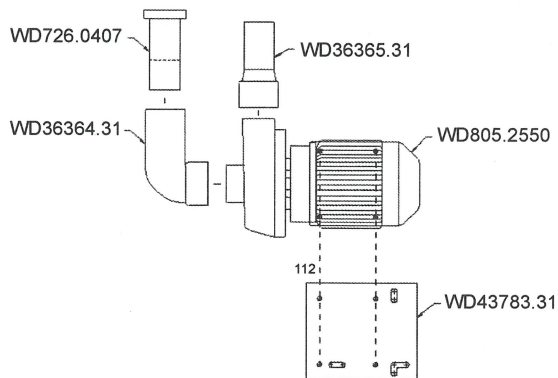

Adapter WD43783.31 is not to be used if the machine is fitted with pump FIR 0251.

This pump has grey colour (engine and pumpbody) and was used between 1997 and 1999.

If this pump is mounted a new hole must be drilled in the attachment (see picture).

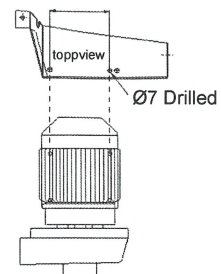
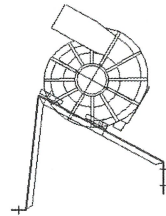

If necessary, also mount the plastic pipe sleeve WD726.0407.

It might be necessary to cut of the sleeve and / or the connection a piece.

If the water pressure should show to be to high in the lower wash arm the delivered restrictor washer can be mounted.

This covers machines built between 1991 to machine no. 012966.

The washer should be placed with the larger diameter upwards and be fastened with the bearing neck.

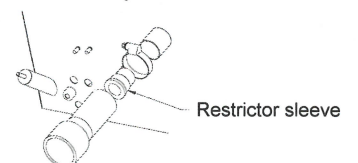
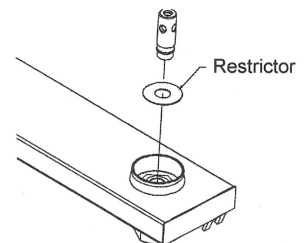

On machines built before 1991 the plastic restrictor sleeve should be mounted at the connection end of the flushing system.

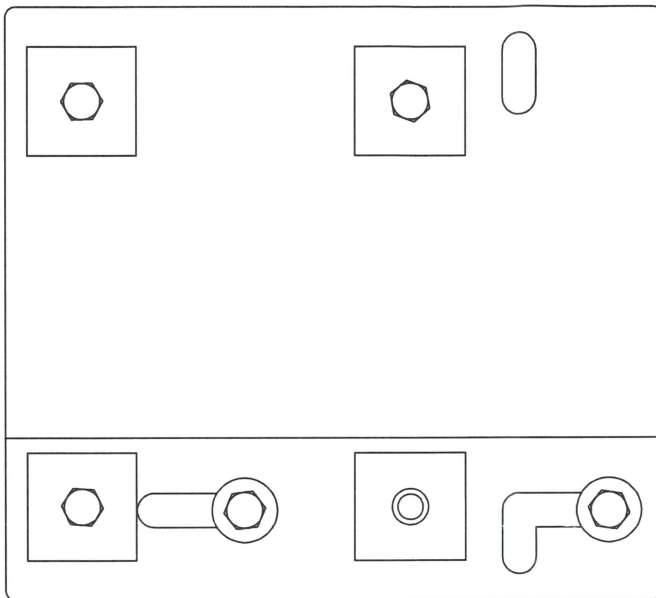
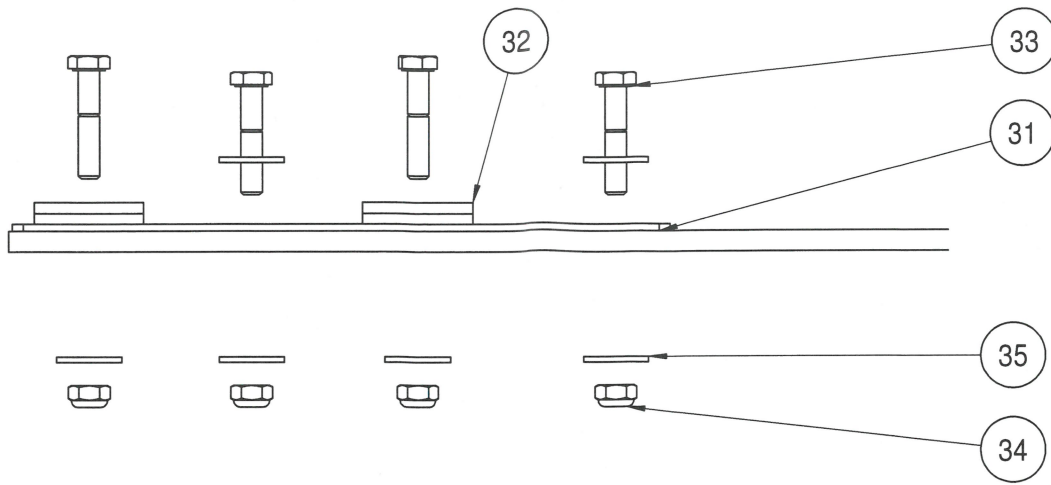

Fäste
Footing

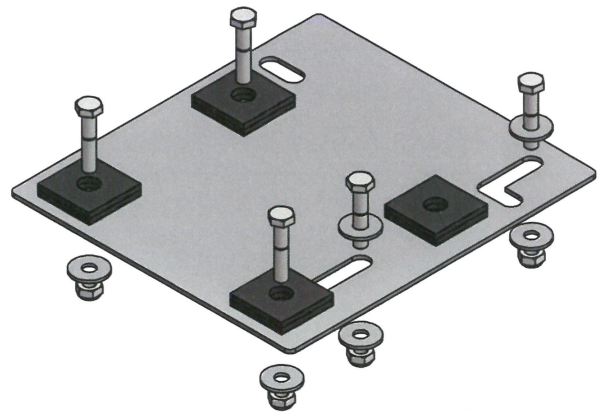

Börja med att montera fästplattan på fästet

Start by mounting the plate on the footing

35	7	Bricka 6,4x18	.	Bet.	.	700,1205		
34	5	LÅSMUTTER			M6	700,1404		
33	5	Skruv M6S			M6X30	700,0118		
32	8	Gummifot 30x30x3				719,1330		
31	1	Adapterplåt	.	Bet.	.	43783,31		
Det	Ant	Benämning	Material	Ytbeh	Dimension	Art. nr		
Konstr.	Ritad	Generell tolerans	Kontr.	Reg.-nr	Godk.	Skala	Ersätter	Ersatt av
MG	MG	SS-ISO 2768 m		5.1				
Wexiödisk Adapterplåt byte diskpump Från P40-12/14 till FIR 2241 WD-6					Filnamn	Dat.		
					46690.DWG	081128		
					Ritn.-nr	Rev.		
					46690			

